



INSTRUCTION MANUAL

Sand Warming Bed Gharieni MLX Quartz



Gharieni Group GmbH
Gutenbergstraße 40
47443 Moers / Germany

➤ Phone:	+49 (0)2841/88300-0
➤ Fax:	+49 (0)2841/88300-999
➤ Distribution department:	+49 (0)2841/88300-300
➤ E-mail:	service@gharieni.com
➤ Web:	www.gharieni.com

You can note the **SERIAL NUMBER** here.
The serial number of the concept bed
is on the rating plate (s. chapter 7. RATING
PLATE).

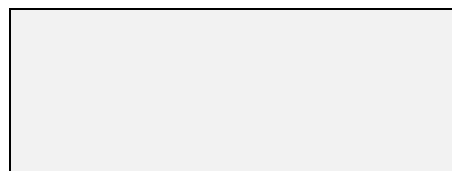

PREFACE

Dear Customer,

we would like to take this opportunity to thank you for purchasing our quality product and for the trust you have placed in us.

Read the complete IM before you use the MLX for the first time.

Reading the complete IM is essential for its proper and safe use and will help you to operate the MLX to your complete satisfaction.

Our MLX is very robust and has a long lifespan when used properly.

Read the instructions very carefully and operate the MLX in its intended use as described only to protect you and your customers from danger.

This is the only way to protect your customers and yourself from dangers resulting from improper use.

Always keep the operating instructions within easy reach near the MLX.

MAKE SURE THAT THIS MANUAL IS AVAILABLE TO ANYONE USING THE MLX AND MAKE SURE THAT IT HAS BEEN READ AND UNDERSTOOD PRIOR TO USING THE CONCEPT BED.

⚠ WARNING! Non-compliance with the instructions in this manual endangers the operator's health and life and / or can damage the MLX.

Index

1. Safety information.....	4
1.1 Abbreviations	4
1.2 Signal words	5
1.3 Safety instructions.....	5
2. Intended use.....	9
3. Scope of delivery	9
4. Prefaces	10
5. Delivery and unpacking	10
5.1 Delivery.....	10
5.2 Unpacking.....	11
6. Transport, space requirements and start-up	12
6.1 Transport.....	12
6.2 Space requirements.....	13
6.3 Start-up.....	13
7. Rating plate.....	14
8. QR-Code.....	14
9. Operation	19
9.1 Height adjustment.....	19
9.2 Inclination - Trendelenburg / anti-Trendelenburg function.....	20
9.3 Glass operating panel	21
9.3.1 Adjustment of the height and inclination function (Trendelenburg).....	22
9.3.2 Locking function	22
9.3.3 Operation of the heating.....	23
9.3.4 Operation of the DynamicFlow system (optional equipment).....	24
9.3.5 Operation of the LED “Spa Ambience Light” (optional equipment).....	28
9.3.6 Operation of the fragrance generator (optional equipment)	28
9.4 Arrow buttons	31
9.5 Reset and initialisation	31
9.5.1 Reset.....	31
9.5.2 Initialisation	31
10. Cleaning and care	32
10.1 Cleaning the material of the upholstery	33

10.1.1	Cleaning and care of the artificial leather	33
10.1.2	Cleaning and care of the polyurethane (PU)	33
11.	Malfunctions (causes and troubleshooting).....	34
11.1	Repair	35
12.	Optional equipment / optional accessories	36
12.1	Upholstery	36
12.2	Gel cushion for nose slits.....	36
12.3	DynamicFlow system.....	37
12.4	LED „Spa Ambience Light“	37
12.5	Fragrance generator	38
12.6	Salt tiles	38
13.	Upholstery care and cleaning agents	39
13.1	mikrozid [®] sensitive (alcohol-free)	39
13.2	Skai cleaner.....	41
14.	Conditions for transport, storage, and operation	42
14.1	Transport	42
14.2	Ambient conditions for storage and transport	42
14.3	Ambient conditions for operation.....	42
15.	Technical data.....	43
16.	Disposal	44
17.	Warranty provisions	45
17.1	Warranty period	45
17.2	Warranty exclusion.....	45
18.	EC-Declaration Of Conformity	46
19.	Status of edition	47



Do not dispose of this appliance together with your domestic waste.

The appliance must be disposed of at a collecting centre for recyclable electric and electronic appliances.

Do not remove the symbol / stickers from the MLX.

1. Safety information

- ❖ When using electrical products / appliances, especially when children are present, basic safety precautions should always be followed, including the following:

READ THE COMPLETE SAFETY INFORMATION AND SAFETY INSTRUCTIONS CAREFULLY BEFORE YOU OPERATE THE MLX FOR THE FIRST TIME.

- **All information included in those pages serve for the protection of the operator. If you ignore the safety information and safety instructions, you will endanger your health and life and as the health and life of your clients.**
- **MAKE SURE THAT THIS MANUAL IS AVAILABLE TO ANYONE USING THE CONCEPT BED MLX QUARTZ AND MAKE SURE THAT IT HAS BEEN READ AND UNDERSTOOD PRIOR TO USING THE CONCEPT BED.**
- This instruction manual is an integral part of the product and must be carefully kept in a safe place to consult it throughout the equipment service life. Copies of this instruction manual are available upon request.
- The Gharieni Group GmbH shall not be held responsible for any damages, direct or indirect, caused to people, animals or objects resulting from negligence or non-compliance with the instructions contained herein.
- Before you dispose of a concept bed or any old appliance, **render it inoperative**. Unplug the concept bed / appliance and cut off the entire power cord. Dispose of the power cord and the plug immediately.

★ Store this manual in a safe place so that it is always at hand when needed. Strictly observe the instructions to avoid damage to persons and property.

1.1 Abbreviations

IM	Instruction manual
MLX	Sand Warming Bed Gharieni MLX Quartz
	Operational advice

1.2 Signal words

⚠ DANGER! indicates a hazardous situation which, if ignored, will result in death or serious injury.

⚠ CAUTION! indicates a hazardous situation which, if not avoided, may result in minor or moderate injury.

⚠ WARNING! indicates a hazardous situation which, if ignored, could result in death or serious injury.

NOTICE! indicates a hazardous situation which, if not avoided, will result in possible damage to the concept bed.

1.3 Safety instructions

⚠ DANGER!

To reduce the risk of electrocution:

1. Non-compliance of the orders of this instruction manual will endanger the life and health of the operator and / or can result in damage to the MLX.
2. All electrical work to connect the MLX to the mains must be carried out by a qualified professional. Do not modify the energy supply. The connection must be carried out in accordance with the current local and legal regulations. **RISK OF ELECTRIC SHOCK!**
3. The technical data of your energy supplier **must** meet the data on the model plate of the MLX.
4. Do not make any changes or manipulations to the MLX and / or its power supply (mains cable, mains plug). In case of unauthorized changes or manipulations, **any** warranty of the manufacturer is excluded.
5. **Do not connect** the MLX to the mains if the concept bed itself or the power cable or the plug are visibly damaged. **RISK OF ELECTRIC SHOCK!**
6. Never try to repair the MLX yourself. If the MLX does not operate properly, please contact the manufacturer or the shop you purchased the concept bed at. Original spare parts should be used only.
7. When the power cable and / or the plug are damaged, it must be replaced by the manufacturer or an authorized aftersales service or a qualified professional only. Never try to repair or replace the power cable and / or the plug yourself. **RISK OF ELECTRIC SHOCK!**

8. **Always** unplug the MLX if it is not used for a longer period.
9. Always disconnect the MLX from the mains before cleaning and / or maintenance. RIKS OF ELECTRIC SHOCK!
10. **Never** pull the power supply cable to unplug the MLX. Always use the power plug itself to unplug the concept bed. RISK OF ELECTRIC SHOCK!
11. **Never** touch the mains plug, mains switch or other electrical components with wet or damp hands. RISK OF ELECTRIC SHOCK!
12. Do not place or store the MLX close to a bath, a shower, or a washbasin. There is danger that the MLX may meet splashed water. RISK OF ELECTRIC SHOCK!

 **WARNING!**

To reduce the risk of burns, electrocution, fire, or injury to persons:

1. Use a properly-grounded socket with proper voltage only (100 - 250 V, 50/60 Hz).
2. **The electric components must not meet water.** RISK OF ELECTRIC SHOCK!
3. Check all cables regularly and contact our Customer Service Department when any cable is in improper condition. RISK OF ELECTRIC SHOCK!
4. Always ensure that the power cord is not bent or squeezed during installation.
5. **Do not** use any extension cords, multiple sockets, or adapters. RISK OF FIRE!
6. **Do not** open the housings of the electric control panels! RISK OF ELECTRIC SHOCK!
7. Liquids **must not** get into the electric control panels! RISK OF ELECTRIC SHOCK!
8. Do not use water or any other liquids while carrying out any application. Do not spill water or any other liquids over, on or into the MLX. Should you spill any water, **immediately** pull the mains plug and dry the MLX thoroughly. RISK OF ELECTRIC SHOCK!
9. Massage oils must not meet with the quartz sand! Only use the oil massage sheet available from Gharieni for oil massage treatments.
10. Never touch the inside of the upper construction, as this will become very hot. RISK OF BURNS!
11. Do not use any other materials, but only the special sand supplied or available from Gharieni for heating.
12. Do not switch on the MLX without the complete special sand filling.

13. **People with acute pain, venous disorders, low blood pressure, inflammatory processes and other medical conditions that make heat applications or this form of client positioning questionable must always consult a doctor before use.**
14. **Never use the MLX on people who are under the influence of alcohol or drugs.**
15. Operate or store the MLX in a dry environment **only**.
16. Close supervision is necessary when the MLX is used by, on, or near children or invalids.
17. Use the MLX only for its intended use as described in this manual. Do not use attachments / accessories not recommended by the manufacturer.
18. Never operate the MLX if it has a damaged cord or plug, if it is not working properly, if it has been damaged or if it has become wet. Return the MLX to an authorized aftersales service for examination and repair.
19. In case of defects or malfunctions of the wellness bed, contact customer service **immediately**. Use of the wellness bed must be discontinued until the problem has been solved to avoid further damage to property and persons.
20. Remove possible dust accumulation at the power plug, at the safety power socket and at all plug connectors **regularly**.
RISK OF FIRE!
21. Keep the cord away from heated surfaces.
22. Never drop or insert any object into any opening.
23. Do not use the MLX outdoors.
24. Do not allow any unauthorized person to operate the MLX!
25. Use the MLX only on a level surface.
26. **Do not place** any objects or liquids on the MLX. The concept bed as well as the material can be damaged thereby.
RISK OF ELECTRIC SHOCK! RISK OF DAMAGE!
27. Any repairs and maintenance work must be carried out by qualified professionals authorized by the Gharieni Group GmbH only!
RISK OF ELECTRIC SHOCK! RISK OF FIRE!
28. **Do not use** a steam cleaner for cleaning. **RISK OF ELECTRIC SHOCK!**
29. **Never** rest or stand on any part of the lying surface or of the upper construction of the MLX. Do not exert strong physical forces on these components; otherwise you can damage the upper construction permanently. **RISK OF TIPPING! RISK OF BREAKAGE! RISK OF INJURY!**
30. Persons, animals, objects or body parts of persons and animals **must not** be positioned between the base and the upper structure.
RISK OF CRUSHING!

31. Persons, animals, objects or body parts of persons and animals **must not** be positioned between parts of the bed.
RISK OF CRUSHING!
32. **Do not** use the supporting structure as a footrest.
33. While unpacking, the packaging materials (polyethylene bags, polystyrene pieces, etc.) should be kept away from children and pets. RISK OF INJURY! CHOKING HAZARD!
34. Always keep children and pets away from the MLX.
35. Children must not play with the MLX or its single components.
36. The MLX is not intended to be operated by persons with reduced physical, sensory, and mental capabilities or lack of experience or knowledge, unless they are supervised or instructed concerning the use of the concept bed and do understand the danger resulting thereof.

NOTICE!

1. For safety reasons, the MLX moves only while pressing one of the arrow buttons or while operating the glass operating panel. When you stop pressing, all moving-operation will stop immediately.
2. **Never** rest, stand, or kneel on any part of the lying / seating surface of the MLX. Do not exert strong physical force on the lying surface or the upper construction; otherwise you can damage the upper construction permanently. RISK OF DAMAGE!
3. To prevent unauthorized use of the MLX, always activate the lock function using the glass operating panel when leaving the treatment room.
4. The rating plate must not be removed or made illegible.
Non-compliance will expire the warranty!

SAVE THESE INSTRUCTIONS.

2. Intended use

Operate the MLX in accordance with its intended use only:

Thermal treatments of the human body using the special sand (the supplied PU-coated sheet separates the sand from the body) at ambient temperatures from +5 °C to +40 °C and a relative humidity from 35% to 65 %; non-condensing at 30 °C.

The normal treatment temperature is 42 °C. The max. temperature is 49 °C. Please always consider that the treatment temperature you have set directly affects the body and organism of the relevant patient.

Any other use is not permitted and will affect the warranty claims.

❖ The MLX Quartz is intended for indoor use **only**.

★ No liability for personal injury or material damage will be accepted if these instructions are not followed.

3. Scope of delivery

Before start-up, check that all components are complete and not visibly damaged.

- Sand Warming Bed including headboard upholstery and nose cone
- 180 kg of quartz sand
- Thermal cover
- Sand cushion (optionally available at an extra charge)
- Upholstery (optionally available at an extra charge)
- Oil massage sheet (optionally available at an extra charge)
- Sand stamps (optionally available at an extra charge)
- Heating apparatus (optionally available at an extra charge)
- PU coated sheet
- INSTRUCTION MANUAL

i If you have purchased optional accessories for your concept bed, these are also included in the scope of delivery.

4. Prefaces

1. The MLX is subject to top quality and safety standards.
2. Some components are made of the naturally-grown raw material wood, which is subject to variations in colour and structure.
3. Even after processing, wood continues to live and therefore, depending on the characteristics of the wood and the ambient climate, cracks and joints may open.
4. The colouring of some models is supported by a stain, which discolours slightly in the first few weeks until the surface oil has fully hardened (not with lacquered surfaces).
5. All the characteristics mentioned in points 2 to 4 do not give rise to any claim.
6. The load capacity of the MLX is 150 kg. The MLX is equipped with two lifting columns; all settings are operated electrically.
With the control element, which is integrated into the frame of the upper construction, you can adjust the height and inclination.
Alternatively, these adjustments can also be made with the glass operating panel.
7. Before using the appliance for the first time, make sure that all parts are present and that there is no visible damage.
8. Make sure that the socket for the concept bed is properly grounded and has the correct voltage rating.



We strongly recommend mixing the quartz sand after heating **before each treatment** to ensure even heat distribution.

5. Delivery and unpacking

5.1 Delivery

If a forwarding agent makes the delivery, the MLX is delivered on a special pallet, protected from external influences with wrapping foil, a solid wooden frame, and cardboard (s. fig.). The MLX is completely horizontal and the upholstery (optionally available at an extra charge) is installed.

The quartz sand is in the lower part of the packaging.



5.2 Unpacking

⚠ WARNING! While unpacking, the packaging materials (polyethylene bags, polystyrene pieces, etc.) should be kept away from children and pets. **CHOKING HAZARD!**

If a forwarding agent makes the delivery, the MLX is delivered on a special pallet, protected from external influences with wrapping foil, a solid wooden frame and cardboard (s. fig.).

The bed is completely horizontal and the upholstery (optionally available at an extra charge) is installed.

To unpack, please proceed as follows:

1. Remove the wrapping foil, the wooden frame, and the cardboard box.
2. Lift the MLX off the pallet **using the four carrying aids** supplied.
3. Remove the carrying aids and stow them safely.
4. Remove the supplied quartz sand from the wooden box in the lower part of the packaging on which the bed stands when delivered.
5. Now fill the quartz sand into the lying surface of the MLX.

6. Transport, space requirements and start-up

6.1 Transport

The bed can be transported by using four removable carrying aids. Screw the 4 carrying aids into the lower metal frame of the upper construction. You need 4 persons to move the MLX to its final site.

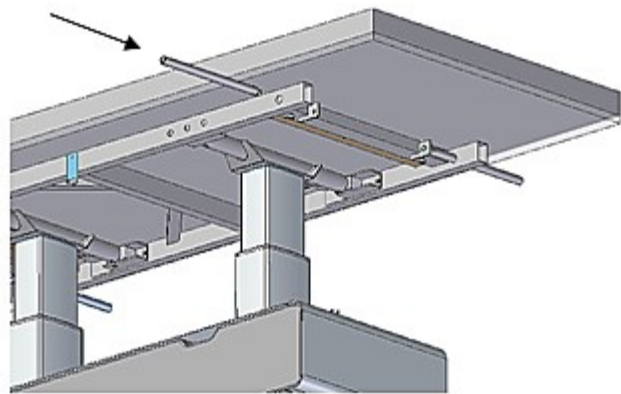

Fig. similar

- i** Always consider the dimensions of the MLX when transporting it. Transporting the MLX can be severely affected by unfavourable environmental conditions. Such unfavourable environmental conditions are e.g. narrow doors, narrow corners behind doors, narrow corridors and hallways, narrow stairways, spiral staircases etc.

The weight of the MLX is at least approx. 170 kg (without quartz sand/upholstery), the length is approx. 220 cm and the width approx. 89.5 cm; please note that the manoeuvrability of the MLX is therefore limited.

- ❖ **Only** transport the bed using the carrying aids supplied.
- ❖ Never lift the MLX by the lying surface during transport; Otherwise you could seriously damage the MLX.
- ❖ When transporting the MLX, consider its total weight, which is approx. 170 kg (without quartz sand/upholstery), so that several people are required for transport.

NOTICE! Do not lift the MLX by the upper construction; otherwise the frame will break.

6.2 Space requirements

Before setting up, make sure that there is enough space for the bed.

The minimum space required is: length = min. 300 cm * width = min. 180 cm.

6.3 Start-up

1. **Allow the MLX to acclimatise for at least 2 hours after delivery before using the bed.**
This allows the temperature sensor to adopt room temperature.
Otherwise, the temperature sensor will output a value that the system cannot process.
2. If the MLX should switch off once when it is switched on due to unplugging or a power failure, the glass operating panel remains black when it is subsequently put into operation.
Disconnect the MLX from the mains and leave the bed de-energised for 5 minutes. Then plug the mains plug back in.
The MLX will now start up normally and return to normal operation.
3. After installation, all control elements must be easily accessible.
The floor must be even, clean, and slip-resistant.
4. **After installation, equip the MLX with the supplied dry special quartz sand only (approx. 180kg; also available from Gharieni). Distribute the sand evenly.**
5. **Never fill more than 180 kg of the special quartz sand!**
6. Place the sand cushions (if available) on the sand, they will be heated automatically.
7. Cover the sand using the supplied thermal cover. Repeat after each treatment to protect the sand from cooling down.
8. Connect the MLX to a properly installed shockproof socket (100 - 250 V, 50/60 Hz, 450 Watt max.) only.
9. Adjust the temperature control to the desired temperature.
The warm-up time is approx. 10 hours. Now you can adjust the temperature (preferably overnight). All electric components are designed for continuous operation. Leave the MLX connected to the mains when used daily.
10. Disconnect the MLX from the mains if you do not use it for a longer period (e.g. vacation).
11. Adjust the height to the lowest level when placing a customer on the MLX.
Then adjust the height to the desired level during treatment (chapter 9.4 and chapter 9.3.1).
12. The sand should perfectly take on the shape of the body for optimal results.
For this purpose, push some sand to the body of your customer.
13. After treatment, adjust the height to the lowest level, so your customer can leave the MLX easily.

7. Rating plate

- ❖ The rating plate is usually in the drawer under the head end of the MLX.
- i** Do not make the rating plate illegible! Do not remove the rating plate! Non-compliance will expire the warranty!



If you wish to contact the Gharieni customer service regarding your concept bed, we recommend taking a photo of the rating plate previously (e.g. using a mobile phone or a digital camera). This makes it easier for you to identify the information of the rating plate (e.g. the serial number of the concept bed) to provide the required information to the customer service. On the cover page of this instruction manual is an area in which you can note the serial number of your concept bed. This way you have the serial number always at hand.

8. QR-Code



In case of service, you can scan the QR-Code using the OCR scan function of a suitable device (e.g. a smartphone). A form will then open via the Internet browser of your device, which already automatically contains the serial number of your MLX. Please describe your problem there and enter your data. You can attach a file from your device memory or take a photo with your device and attach it. To do this, tap on the "Select file" button. A window with options will then open. The appearance of this window may differ from the illustration, depending on your device and operating system. After you have confirmed that you have read our data protection guidelines by marking the box at the end of the form, the form with all the entries you have made is immediately sent to our customer service department by clicking "Send".

- ❖ The QR-Code is in the drawer under the head end of the MLX.



B	QR-CODE
----------	---------

(Figure similar, position differs)

Serial number (Complete as written on nameplate) /
Seriennummer (Komplett wie im Typenschild) /
Numéro de série (Complet comme inscrit sur la plaque d'identification)

KoM4-3A-M1-SUPERSOFT-SM-RAL9007-0530

Please describe the issue* (Required Field) /
Bitte schildern Sie das Problem * (Pflichtfeld) /
Veuillez s'il vous plait décrire le problème* (Champ obligatoire)

Add file: / Datei hinzufügen: / Ajoutez un fichier:

Datei auswählen Keine ausgewählt

Your address / Ihre Adresse / Votre adresse

First and last name* (Required Field) /
Vor- und Zuname * (Pflichtfeld) /
Prénom et nom* (Champ obligatoire)

Company / Firma / Entreprise

Street adress /
Strasse und Hausnummer /
Rue et numéro de rue

ZIP Code* (Required Field) /
Postleitzahl* (Pflichtfeld) /

Figure shows form that opens in the Internet browser of the device after the QR code is scanned.

Code postal* (Champ obligatoire)

City* (Required Field) /
Stadt* (Pflichtfeld) /
Ville* (Champ obligatoire)

E-Mail-Adress* (Required Field) /
E-Mail-Adresse* (Pflichtfeld) /
Votre adresse e-mail* (Champ obligatoire)

Phone number* (Required Field) /
Telefonnummer* (Pflichtfeld) /
Téléphone* (Champ obligatoire)

I read the privacy policy of the Gharieni Group.
Ich habe die [Datenschutzrichtlinien](#) der Gharieni Group gelesen.< /br> J'ai lu la [protection des données](#) du Groupe Gharieni.

SEND

Figure shows form that opens in the Internet browser of the device after the QR code is scanned.

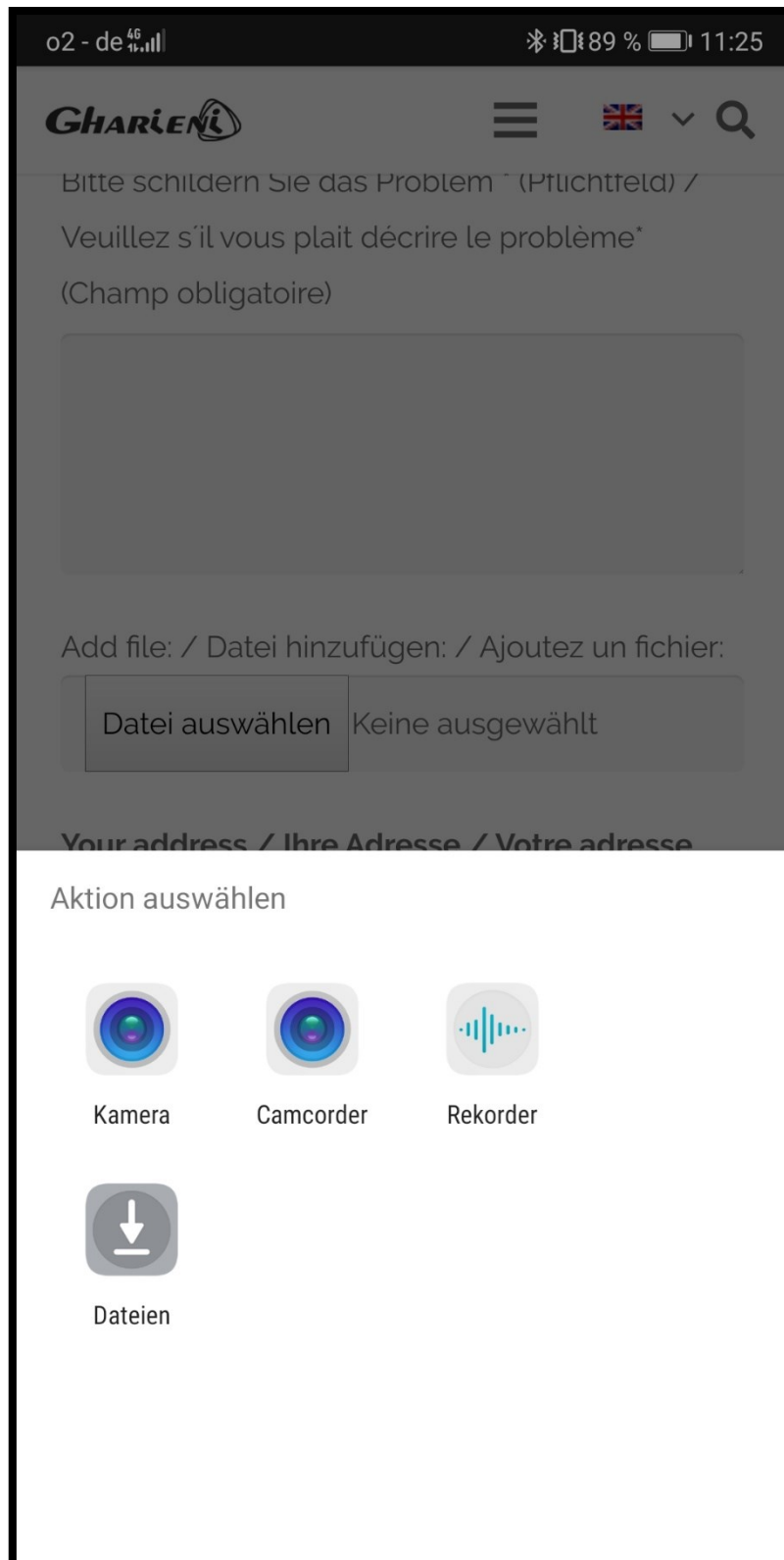

*Figure similar: option window for adding a file.
Appearance may vary depending on the device and operating system.*

9. Operation

9.1 Height adjustment

You can adjust the height from approx. 63 cm to approx. 88 cm.

The entrance height is approx. 63 cm, so your customer has easy access to the MLX.

The height adjustment is operated electrically.

Touch the relevant control elements (chapter 9.4), alternatively, the height can be adjusted using the glass operating panel at the head end of the MLX (s. chapter 9.3.1).

NOTICE! For safety reasons, the MLX only moves if you touch the glass operating panel or press the arrow keys. When released, the movement stops immediately.

The two lifting columns can be operated individually so you can move your customer into the so-called Trendelenburg position.

The upholstery of the headrest has an opening for the nose usable when carrying out back massages. The cover plug of the opening is removable.

Using a gel cushion (s. fig. below; optionally available at an extra charge) on the headrest upholstery can additionally support the face of the person to be treated.



9.2 Inclination - Trendelenburg / anti-Trendelenburg function

By pressing the corresponding areas on the glass operating panel (s. chapter 9.3.1) or the arrow buttons (s. chapter 9.4) you can set the inclination of the lying surface up to +/- 16°. The MLX will move up automatically unless it has reached a sufficient height while adjusting the inclination to avoid collision with the base.

The two lifting columns can be operated individually so you can move your customer into the so-called Trendelenburg position.



During the transition from Trendelenburg to anti-Trendelenburg, the MLX stops for one second in horizontal position.

If you continue to hold the button down, the MLX will continue to move.

⚠️ WARNING! Do not use the base as a footrest.

⚠️ WARNING! There must be no objects between the box below the bed and the upper construction. RISK OF COLLISION!

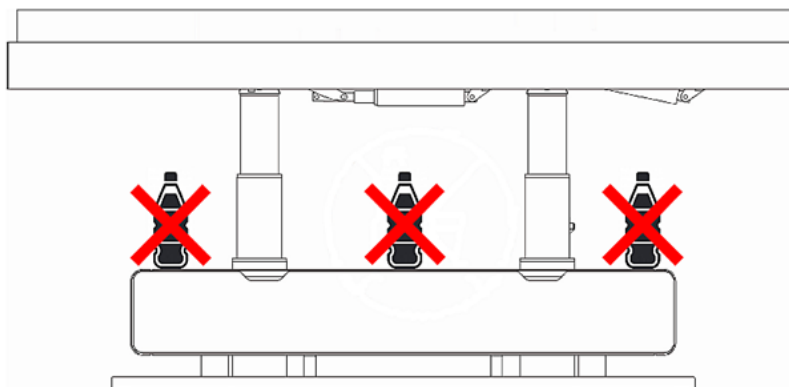

9.3 Glass operating panel

The glass operating panel on the foot end of the MLX is used to adjust the height and the inclination of the lying surface, to operate the optional DynamicFlow, the optional LED system “Spa Ambience Light”, the optional fragrance generator and to adjust the temperature of the heating.

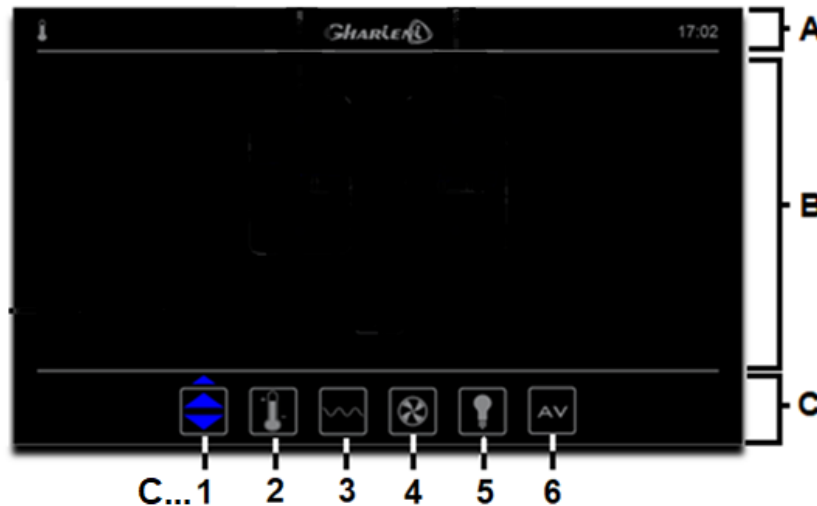

A	STATUS BAR of the glass operating panel
B	OPERATION BAR of the glass operating panel (for adjustment of the height, the inclination, the heating, the Dynamic Flow System, the fragrance generator, and the LED “Spa Ambience Light”)
C	FUNCTION BAR of the glass operating panel
C 1	Button to activate the adjustment of the HEIGHT and INCLINATION.
C 2	Button to activate the adjustment of the HEATING SYSTEM.
C 3	Button to select the DYNAMIC FLOW SYSTEM (optional equipment)
C 4	Button to activate the adjustment of the FRAGRANCE GENERATOR for aroma therapy (optional equipment)
C 5	Button to activate the adjustment of the LED “SPA AMBIENCE LIGHT” (optional equipment)
C 6	VIDEO (not available)

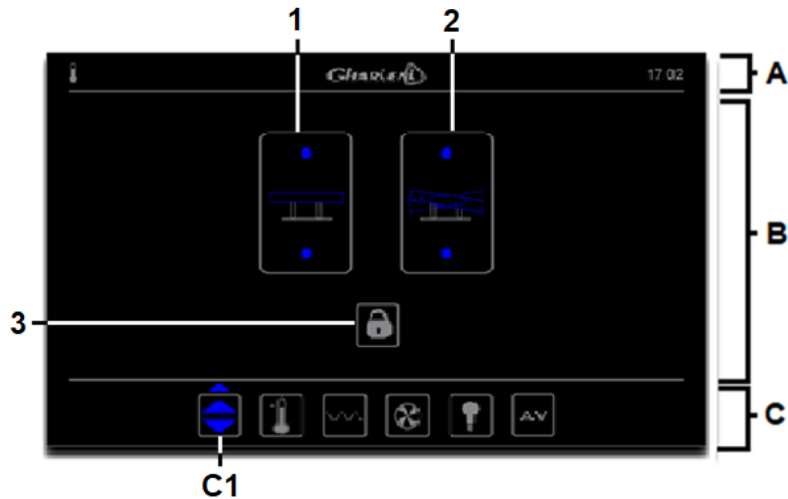

C 1	Button to activate the adjustment of the HEIGHT and INCLINATION
1	Button to adjustment the HEIGHT
2	Button to adjustment of the INCLINATION
3	Button / icon of the LOCKING FUNCTION (lock / unlock)
A	STATUS BAR
B	OPERATION BAR
C	FUNCTION BAR

9.3.1 Adjustment of the height and inclination function (Trendelenburg)

In the function bar, (s. fig. in chapter 9.3 GLASS OPERATING PANEL), select the symbol for adjustment of the bed.

Then the height and the inclination function of the bed can be adjusted using the operation bar.

9.3.2 Locking function

The locking function prevents unintentional adjustment of the bed.

1. Touch the lock symbol in the operation bar for approx. 4 seconds (s. fig. in chapter 9.3 GLASS OPERATING PANEL).
2. The symbol changes colour to orange.
A smaller lock symbol now appears in the status bar.
3. The bed is now locked.
4. To unlock, touch the lock symbol again for approx. 4 seconds.

9.3.3 Operation of the heating

1. Select the thermometer symbol for the heating in the function bar (s. fig. in chapter 9.3 GLASS OPERATING PANEL).
2. Now set the target temperature in the operation bar.
The value is shown in brackets in the status bar, 20 °C to 50 °C.
The actual temperature is displayed next to it.
3. Switch on the heating by touching the “On” / “Off” area.
The symbol changes colour from white to blue.
If the adjusted temperature is adjusted higher than the actual temperature, the heating heats up.
In this case, the thermometer symbol flashes in the status bar.

If a day of the week is selected (s. fig. below), the heating switches on at 12 o'clock PM on this day.

This function is helpful because the heating needs approx. 6-8 hours to heat up the quartz sand from 20 °C to approx. 50 °C.

Example: You switch off the heating on Friday evening and then touch the symbol “M” for Monday.

The heating switches on at 12 o'clock PM on Monday.

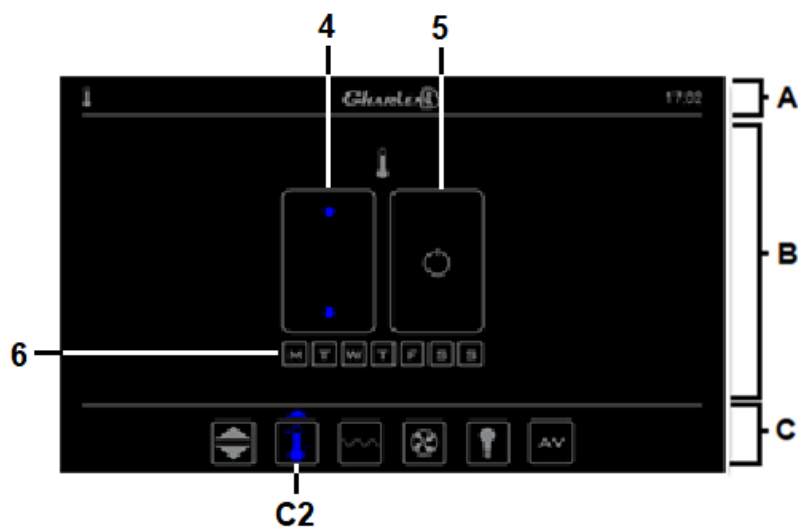

C 2	Button to activate the adjustment of the HEATING
4	Button to adjust the desired TEMPERATURE (from 20 °C to 50 °C)
5	Button to switch on / off the HEATING
6	Buttons to select a DAY OF THE WEEK (from Monday to Sunday)

9.3.4 Operation of the DynamicFlow system (optional equipment)

1. Select the wave symbol for DynamicFlow in the function bar (s. fig. in chapter 9.3 GLASS OPERATING PANEL).
2. Now touch the symbol for program 1 in the operation bar (wave-shaped, continuous inflation of the air cushions and release of the air in both directions: Rhythm: “1-2-3-4-5, 4-3-2-1, 2-36...”) or the symbol for program 2, here the wave is always created from below -starting from the head side- in the direction of the foot end through the air cushions (rhythm: “1-2-3-4-5, 1-2-3-4-5, 1-2-3...”), s. figures. The running time of the two programs is 15 minutes each.

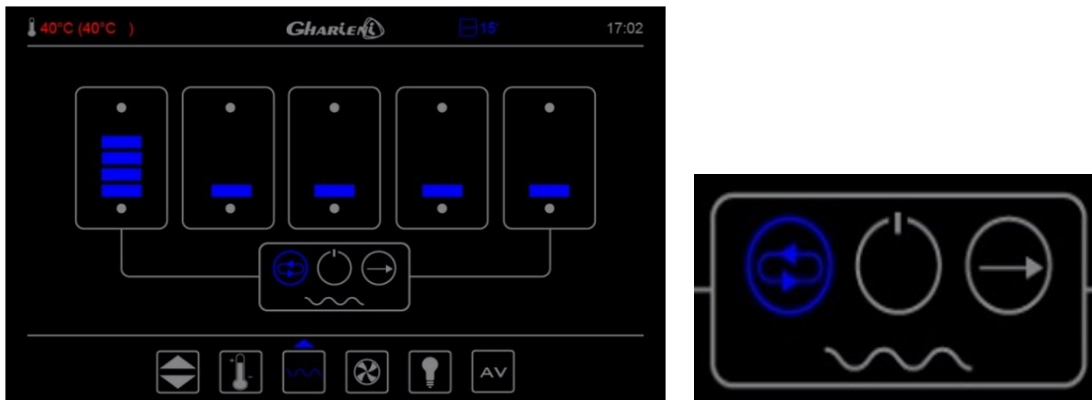

Fig. shows selected program 1

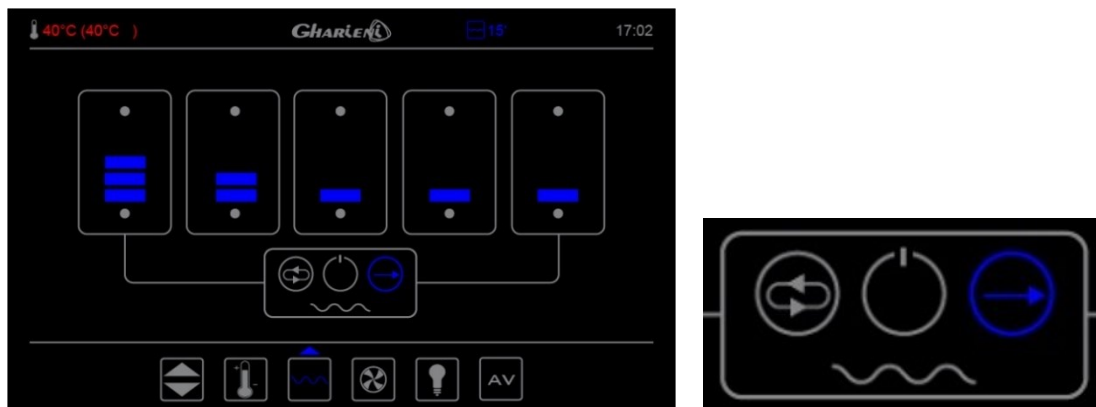

Fig. shows selected program 2

3. After the program running time has elapsed, there is always a 6-minute cool-down phase ($\cong 360$ seconds), s. figure.
The 360 seconds are displayed in the status bar and run down to 0, this is shown in blue letters. During the cool-down phase, a red lock is displayed instead of the symbol for the two programs.

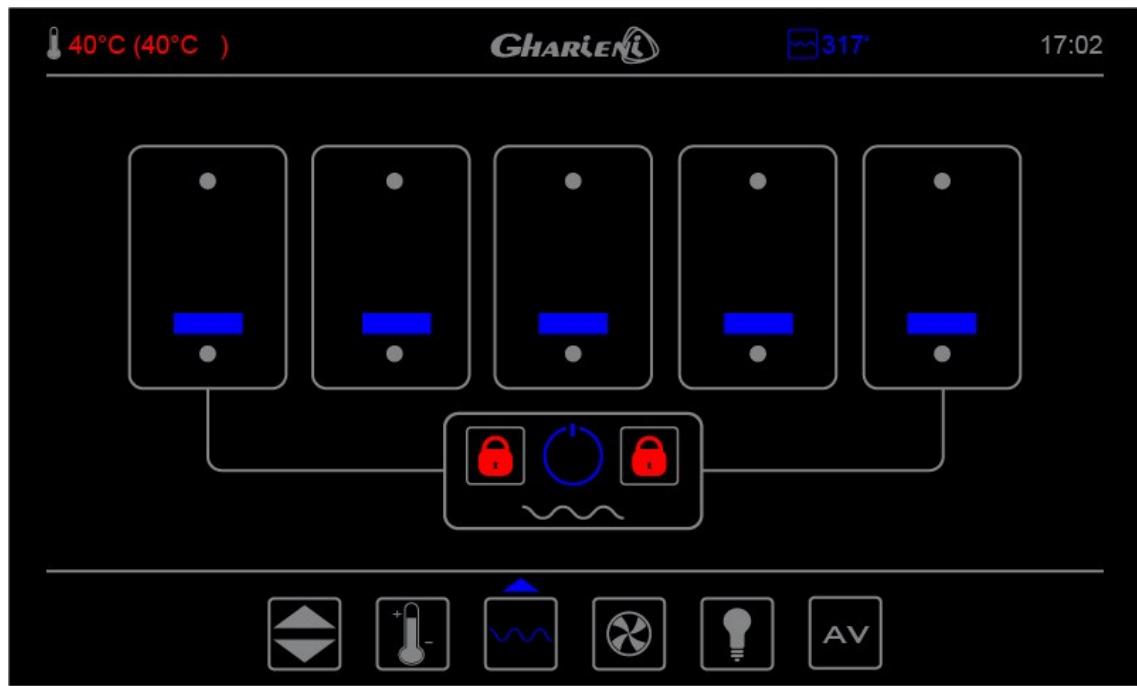

Fig. shows the cool-down phase (360 sec.) after the program running time has elapsed

Before the end of the cool-down phase, only manual inflation of the air cushions is possible. After the cool-down phase has been completed, the system returns to standby mode (s.fig.), the red lock in place of the symbols for the two programs disappears. Now a program can be started again, or the air cushions can be manually inflated or deflated individually (s. point 6).

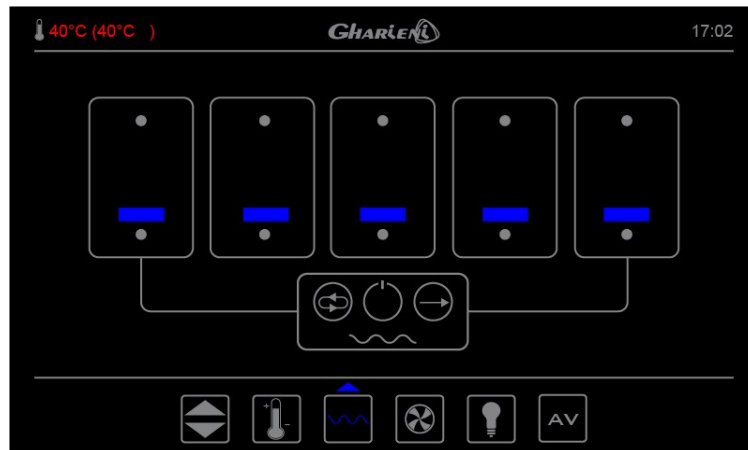

Fig. shows stand-by mode after cool-down phase has been completed

NOTICE! An active program can be cancelled.

4. Cancel program:

If one of the programs is already active, but you want to start the other program, for example, you can cancel the active program at any time by touching the corresponding button on the glass operating panel again.

If the program is interrupted prematurely within the first minute of the program running time, the cool-down phase is skipped, and the other program can be started. However, if the program is interrupted after the first minute, the 6-minute cool-down phase must be waited for.

The 360 seconds are displayed in the status bar and run down to 0, this is shown in blue letters. After the cool-down phase, the system returns to stand-by mode (s. fig.). The red lock in place of the symbols for the two programs disappears. Now a program can be started again.

5. Manual control of the air cushions:

In addition to the two programs, the air cushions can be controlled manually (s.fig.). The status of the air cushion is visualized by up to five horizontal bars in the area for the respective air cushion (s. fig.).

After 2 seconds the second bar appears, after 4 seconds the third, after 6 seconds the fourth and after 8 seconds the fifth bar.

When all five bars are visible, the pump stops.

Further inflation is not possible. Now the air can only be released.

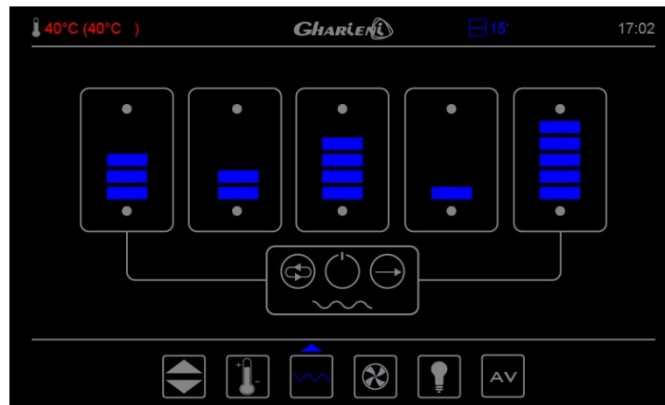

Fig. shows the glass operating panel when air chambers have been inflated manually

For step-by-step inflation or deflation, touch the button (white dot at the bottom/top) of the respective air cushion and keep this button pressed to inflate the air cushion with the desired amount of air or to deflate the air to the desired extent.

To deflate completely, touch the “On / Off” button.

Red locks appear in place of the symbols for the two programs until the air has been completely released (s.fig.). The system then returns to stand-by mode.

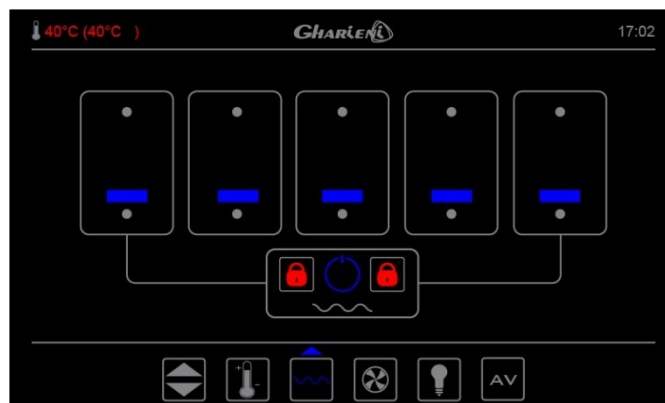

Fig. shows the glass operating panel when the air is released from the air cushions after they have been inflated manually

NOTICE! As soon as you stop touching the respective button on the glass operating panel, inflation or deflation stops immediately.

During the 6-minute cool-down phase (after the end of the program), the air cushions can still be inflated or deflated after 15 seconds of deflation have elapsed.

9.3.5 Operation of the LED “Spa Ambience Light” (optional equipment)

1. Select the light bulb symbol for the LED “Spa Ambience Light” in the function bar (s. fig. in chapter 9.3 GLASS OPERATING PANEL).
2. Now touch the desired color directly in the operation bar (s. fig. below).
3. The remaining time (60, 90 or 120 minutes) is displayed in the status bar.

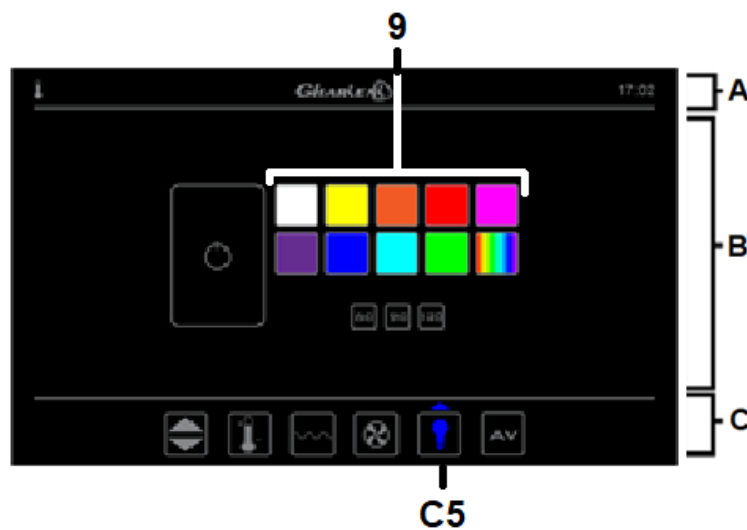

C 5	Button to activate the adjustment of the LED “SPA AMBIENCE LIGHT”
9	SELECTABLE COLOURS (activation of the LEDs)

9.3.6 Operation of the fragrance generator (optional equipment)

1. Select the fan symbol for the fragrance generator in the function bar (s. fig. in chapter 9.3 GLASS OPERATING PANEL).
2. Select the desired running time (60, 90 or 120 minutes).
3. Now touch the area 1, 2 or 3 in the operation bar to select the desired fragrance chamber (s. fig. below). The symbol turns blue.
4. The remaining time (60, 90 or 120 minutes) is displayed in the status bar.

The fragrance is emitted in the head area, s. fig.

NOTICE! Fill the fragrance chambers with appropriate fragrance pellets before use.

NOTICE! To avoid confusing the fragrances, the lids of the fragrance chambers are marked with the numbers 1 to 3, s. fig.

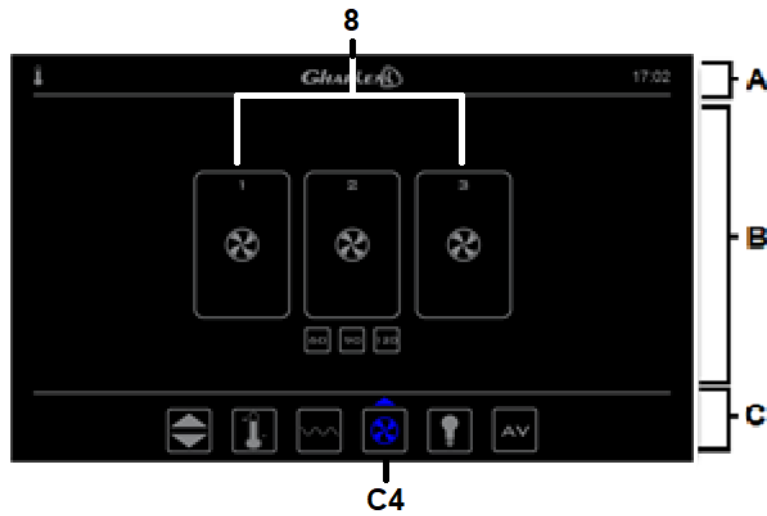

C 4	Button to activate the adjustment of the FRAGRANCE GENERATOR for aroma therapy
8	Buttons to select and activate the FRAGRANCE CHAMBERS 1, 2 or 3

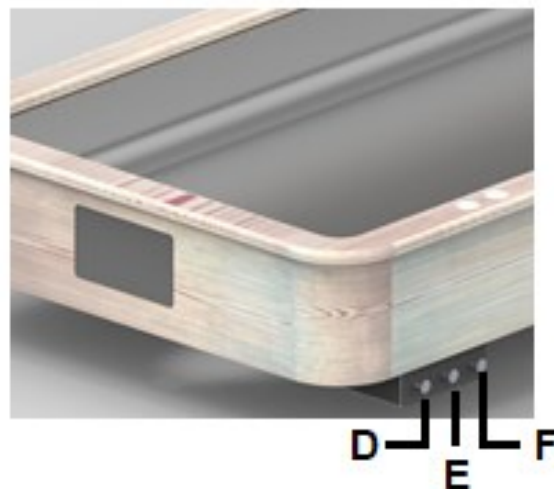

D	FRAGRANCE CHAMBER 1
E	FRAGRANCE CHAMBER 2
F	FRAGRANCE CHAMBER 3

i To avoid confusion of the fragrances, the numbers 1 to 3 are on the lids of the fragrance chambers (s. fig. below).



G

NUMBERING OF THE FRAGRANCE CHAMBER



9.4 Arrow buttons

You can adjust the height and inclination using the arrow buttons on the frame of the MLX.

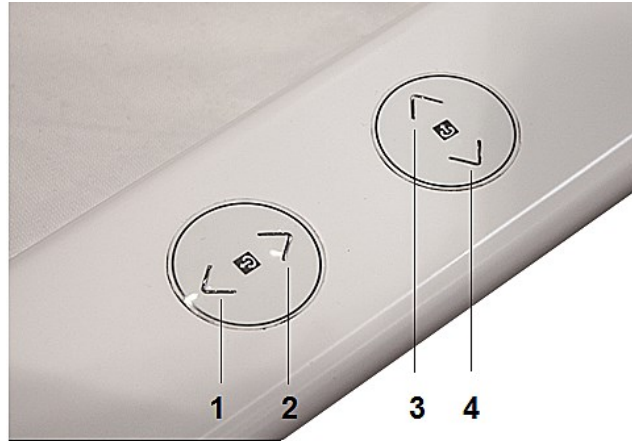

- | | |
|---|-------------------------|
| 1 | Inclination downwards |
| 2 | Inclination upwards |
| 3 | Lying surface upwards |
| 4 | Lying surface downwards |

9.5 Reset and initialisation

9.5.1 Reset

Press both arrow buttons for height adjustment of the MLX simultaneously and hold them down for approx. 10 seconds.

The control box of the bed emits a signal tone.

When the signal tone stops, the reset process is complete.

9.5.2 Initialisation

Now lower both lifting columns step by steps alternately using the two arrow buttons of the height adjustment button **until the lifting columns have reached their end position.**

10. Cleaning and care

⚠ WARNING Disconnect the MLX from the mains (unplug) before cleaning and maintenance. **RISK OF ELECTRIC SHOCK!**
RISK OF FIRE!

⚠ WARNING! Remove possible dust accumulation at the power plug, at the safety power socket and at all plug connectors **regularly**.
RISK OF FIRE!

⚠ WARNING! Ensure that water or other liquids cannot get into the glass operating panel or into the arrow buttons.
RISK OF ELECTRIC SHOCK! RISK OF FIRE!

- ❖ **Do not wear** any arm and finger decoration such as rings or bracelets while carrying out any cleaning or maintenance operations. Otherwise, you can scratch and damage the upholstery and / or the material of the base of the MLX unintentionally.
- ❖ Use water or a mild cleaning agent which is suitable for the material **only**.
- ❖ **Do not use** extremely hot water to clean the MLX.
- ❖ **Do not use** any sponges, scouring pads or floor clothes.
- ❖ **Do not use** any aggressive cleaning agents such as scouring powders, floor cleaners, etc.
- ❖ **Do not use** any dishwashing detergents.
- ❖ **Do not use** any solvents or bleaching agents.
- ❖ **Do not use** any essential oils.
- ❖ Clean the housing and the fittings only with a damp cloth or sponge and a little soap.
- ❖ The special sand should be replaced as needed, but after 12 months at the latest. Contaminated special sand, e.g. by oils, should be removed immediately and replaced with the same amount of new special sand.
- ❖ The inner box and sheet metal cover can be cleaned with a suitable disinfectant.
- ❖ All natural wood parts are treated with a special wood oil and may only be cleaned with water 12 weeks after production.
Before that, you may only use a dry cloth or care oil approved by the manufacturer. This can also be used to refresh the surface.
Please note: A surface that is regularly refreshed retains its beautiful appearance for a very long time and is easy to maintain.
- ❖ Upholstery: The optional upholstery for the MLX, available from Gharieni for an additional charge, is made of PU (polyurethane) or artificial leather.

NOTICE! Damage of the upholstery and / or of the material of the base / upper structure caused using unsuitable cleaning agents **is not subject to the guarantee or the warranty!**

10.1 Cleaning the material of the upholstery

- ❖ The optionally available upholstery is either made of **ARTIFICIAL LEATHER** or **POLYURETHANE (PU)**.

10.1.1 Cleaning and care of the artificial leather

- ❖ Clean the artificial leather **only** with a soft cloth with a small amount of a detergent suitable for this material (also available from Gharieni: see chapter 13. UPHOLSTERY CARE AND CLEANING AGENTS).

10.1.2 Cleaning and care of the polyurethane (PU)

- ❖ Clean the PU using a soft cloth **only** provided with a small amount of a detergent suitable for this material (also available from Gharieni: see chapter 13. UPHOLSTERY CARE AND CLEANING AGENTS).

11. Malfunctions (causes and troubleshooting)

MALFUNCTION	
POSSIBLE CAUSE(S)	TROUBLESHOOTING
ALL ACTUATORS DO NOT WORK.	
<ol style="list-style-type: none"> 1. No connection to the mains. 2. The power supply cable is damaged. 3. Fuse in the transformer is defective. 4. Control box total loss. 	<ol style="list-style-type: none"> 1. Check the connection status. 2. Power supply cable must be replaced (please contact the customer service). 3. Fuse must be replaced (please contact the customer service). 4. Control box must be replaced (please contact the customer service).
SINGLE ACTUATOR DOES NOT WORK.	
<ol style="list-style-type: none"> 1. Lifting column plug is not connected properly. 2. Control box is defective. 3. Lifting column cable / plug is defective. 4. Lifting column is defective. 	<ol style="list-style-type: none"> 1. Connect plug properly. 2. Control box must be replaced (please contact the customer service). 3. Cable / plug must be replaced (please contact the customer service). 4. Lifting column must be replaced (please contact the customer service).

NOTICE! If the MLX is disconnected from the mains while switched on by pulling the plug or by a power failure, the glass operating panel will remain black during subsequent start-up.

Disconnect the MLX from the mains and leave the bed disconnected for 5 minutes. Then plug the mains plug back in.

The MLX will now start up normally and return to normal operation.

i If the concept bed shows a malfunction not noted on the schedule above or if you have checked all items on the above schedule but the problem still exists, please contact the customer service (s. chapter 11.1 REPAIR).

11.1 Repair

YOU CAN CONTACT THE GHARIENI CUSTOMER SERVICE USING THE FOLLOWING CONTACT INFORMATION:

CUSTOMER SERVICE HOTLINE:	+49 (0)2841/88300-40
E-MAIL:	service@gharieni.com

1. Always provide the **serial number** when contacting Gharieni customer service.
2. We consider ourselves responsible for the safety and reliability of the MLX Quartz only if the repairs and modifications are carried out by us or a person authorised by us. Furthermore, the electrical installation of the room must comply with the regulations and the concept bed must be used in accordance with the operating instructions.
3. The MLX is designed for continuous operation. It is equipped with an overload protection as additional security. As an additional safety feature, overload protection has been built in, which switches the MLX off and on again automatically if the thermostat fails at 75 °C.
4. The temperature sensor is in front of the aluminium-made angular cover plate in the bottom section of the inner tray (close to the control elements). The temperature sensor must not be damaged.
5. In the event of improper modifications or manipulations to the concept bed, any warranty of the manufacturer is excluded.
6. All electric components are designed for continuous operation. Leave the MLX connected when it is used every day.
7. Check the power cord regularly for damage.
8. If the power cable is damaged, it must be replaced by the manufacturer or an authorized aftersales service or a qualified professional (electrical technician) only.



If you wish to contact the Gharieni customer service regarding your concept bed, we recommend taking a photo of the rating plate previously (e.g. using a mobile phone or a digital camera). This makes it easier for you to identify the information of the rating plate (e.g. the serial number of the concept bed) to provide the required information to the customer service.

On the cover page of this instruction manual is an empty field in which you can enter the serial number of your concept bed. This way you have the serial number always at hand.

12. Optional equipment / optional accessories

12.1 Upholstery

With the four optional upholstery cushions, available from Gharieni at an extra charge, the MLX can additionally be used for massages (s. figures below).



12.2 Gel cushion for nose slits

- ❖ A GEL CUSHION for the head part of the MLX is optionally available for an extra charge.
- ❖ Optimal for the prone position (massage position).
- ❖ By placing a FACE GEL CUSHION (s. fig. below) on the upholstery of the head part the face of the person to be treated can also be supported.
- ❖ Using the GEL CUSHION can also prevent pressure marks on the face of your clients.
- ❖ In addition, the face is pleasantly cooled by the soft gel fluid.



GEL CUSHION FOR NOSE SLITS

ITEM NUMBER: 45010

- ★ Please contact our distribution department regarding the right size and the suitable design for your bed. Our team will be happy to help!

12.3 DynamicFlow system

Intensify every quartz treatment with the fully integrated massage system that gently massages the neck and back.

Pre-programmable, this air massage system can be filled with air or deflated to create a wave-like sensation that your clients can enjoy simultaneously with a traditional massage or other treatment.

The air massage system with 5 chambers can be used as a massage program or as a 3-point lumbar support. The massage moves in waves by inflating and deflating the individual chambers.

The system can only be operated with the glass operating panel.



- s. also chapter 9.3.4 OPERATION OF THE DYNAMICFLOW SYSTEM (OPTIONAL EQUIPMENT).

12.4 LED „Spa Ambience Light“

The integration of the LED “Spa Ambience Light” in the MLX Quartz allows the client to fully immerse in the treatment with targeted lighting.

This chromotherapy has a calming or stimulating effect on body and mind, depending on the color selected.

Operation exclusively with the glass operating panel.

- s. also chapter 9.3.5 OPERATION OF THE LED “SPA AMBIENCE LIGHT” (OPTIONAL EQUIPMENT)

12.5 Fragrance generator

A new Gharieni innovation that adds an olfactory component and makes the treatment multisensory.

Fragrance chambers diffuse a pre-selected scent that envelops the client while lying on the bed.

Tiny diffusors located in the head area of the bed (s. fig. below) release aromas to gently transport the client into bliss.

Operation exclusively with the glass operating panel.



- s. also chapter 9.3.6 OPERATION OF THE FRAGRANCE GENERATOR (OPTIONAL EQUIPMENT)

12.6 Salt tiles

Illuminated and heated salt tiles, which can optionally be integrated into the sided of the bed, generate negative ions to purify the air, s. fig. below.



13. Upholstery care and cleaning agents

13.1 mikroqid[®] sensitive (alcohol-free)

- ❖ We recommend mikroqid[®] sensitive for gentle and thorough care and cleaning of the upholstery.
- ❖ mikroqid[®] sensitive removes bacteria, fungi, and viruses (e.g. HBV, Rota, Vaccinia etc.).
- ❖ mikroqid[®] sensitive is available as liquid.
- ❖ **Suitable for cleaning of PU and artificial leather upholstery.**
- ❖ **Without alcohol!**



MIKROZID[®] SENSITIVE LIQUID

ITEM NUMBER: 79417

Microbiological efficacy

Efficacy	Concentration	Contact time
bactericidal <i>in accordance with VAH Guidelines with short contact times</i>	ready-to-use	1 min.
MRSA	ready-to-use	1 min.
levurocidal <i>in accordance with VAH Guidelines with short contact times</i>	ready-to-use	1 min.
virucidal against enveloped viruses <i>in accordance with DVV (German Registered Association for Combating Viral Diseases)//RKI Guideline</i>	ready-to-use	1 min.
Norovirus EN14476	ready-to-use	15 min.
Polyoma SV40	ready-to-use	1 min.
Rotavirus	ready-to-use	1 min.

Certificates

- VAH certificate
- IHO listed



CE 0297

13.2 Skai cleaner

- ❖ For gentle and thorough care and cleaning of the artificial leather upholstery we additionally recommend Skai cleaner.
- ❖ Skai cleaner is available in a 200 ml spray bottle.
- ❖ **Especially suitable for cleaning artificial leather.**



SKAI CLEANER

ITEM NUMBER: 79427

14. Conditions for transport, storage, and operation

14.1 Transport

- ❖ **Never** carry the MLX by its upper construction; otherwise you can seriously damage the MLX.
- ❖ Always consider the total weight of the MLX which is approx. 170 kg (without quartz sand/upholstery). You may need the help of several persons.
- ❖ **Always** consider the dimensions of the MLX.
Narrow hallways, doors or staircases can make the transport difficult or impossible.

14.2 Ambient conditions for storage and transport

TEMPERATURE	from - 10 °C to + 50 °C (ambient temperature)
ATMOSPHERIC PRESSURE	from 700 to 1060 hPa
RELATIVE HUMIDITY	from 20 % to 70 % at +30 °C non-condensing

14.3 Ambient conditions for operation

TEMPERATURE	from + 5 °C to + 40 °C (ambient temperature)
ATMOSPHERIC PRESSURE	from 700 to 1060 hPa
RELATIVE HUMIDITY	from 35 % to 65 % at +30 °C non-condensing

15. Technical data

Functional description of the heating:

The resistance heating below the lying surface supplies heat evenly to the special sand. A temperature sensor regulates the temperature of the sand.

GENERAL DATA

Overall dimensions (length*width*height)	220*89,5*88 cm
Lying surface (length*width)	202*72 cm
Base (length*width)	150*60 cm
Height adjustment range	63-88 cm
Trendelen/anti-Trendelenburg	yes
Inclination	+/- 16°
Lifting capacity	150 kg
Lifting capacity (max. safe working load)	130 kg
Weight without sand/upholstery	approx.170 kg
Weight of the quartz sand	approx. 180 kg

❖ Subject to technical changes.

ADJUSTMENT DRIVES INCL. CONTROL

Transformer power primary	230V AC/50Hz/200 VA max.
Transformer power secondary	24 V DC
Fuse	3 Ampere AT
Duty cycle (drives)	10 % max. 2 Min. continuous operation/18 min. break
Mains connection cable	3m, cord
Equipment protection class	I with heating, otherwise II
Protection class against electric shock	Type B
Protection class against penetration of substances	IP X4

❖ Subject to technical changes.

HEATING

Power	300 W
Current voltage secondary	24 V AC/50Hz
Fuse	2*1,6 AT

❖ Subject to technical changes.

16. Disposal

1. While unpacking, the packaging materials (polythene bags, polystyrene pieces, etc.) should be kept away from children and pets. **CHOKING HAZARD! RISK OF INJURY!**
2. Do not dispose of the MLX together with your domestic waste. Old and unused concept beds must be sent for disposal to the responsible recycling centre for electric appliances. Do not remove the relevant symbol from the product.
3. **Never** expose to open flames.
4. The concept bed should be cleaned thoroughly before disposal to protect persons, environment, and materials.
5. Before you dispose of a concept bed or any old appliance, **render it inoperative**. Unplug the concept bed / appliance and cut off the entire power cord. Dispose of the power cord and the plug immediately.
6. The MLX is made of metal and plastic components, electronic components, electric cables. Dispose of the separate components in accordance with the current local disposal regulations.
7. Dispose of any paper and cardboard into the corresponding containers.
8. Dispose of any plastics into the corresponding containers
9. If suitable containers are not available at your residential area, dispose of these materials at a suitable municipal collection point for waste recycling.
10. Receive more detailed information from your retailer, municipal facilities or:

Gharieni Group GmbH

➤ Phone:	+49 (0)2841/88300-0
➤ Fax:	+49 (0)2841/88300-999
➤ Customer service hotline:	+49 (0)2841/88300-40
➤ E-mail:	service@gharieni.com



Materials marked with this symbol are recyclable.



Please contact your local authorities to receive further information.

17. Warranty provisions

17.1 Warranty period

The following guarantee provisions apply to new goods worldwide:

The Gharieni Group GmbH offers for all concept beds of the MLX Quartz series

- a 10-year warranty for their metal frames,
- a 5-year warranty for their actuators and
- a 3-year warranty for their other components.

17.2 Warranty exclusion

Upon delivery, it is necessary to check that the equipment has not been damaged during transportation and that the set of accessories is complete and in good condition.



Claims must be filed within 8 days after the delivery of the Gharieni product.

Wearing parts (such as e.g. all types of lamps as well as glass panels, consumables such as terry products, etc.) are not covered by this warranty.

Apart from the cases specified in the supply agreement, the guarantee is void when:

- damage has been caused by improper use of the concept bed and its associated components.
- damage of the concept bed and its associated components has been caused by gross negligence.
- the malfunctioning is attributable to the operator.
- any stickers (such as e.g. the rating plate, instruction notices, etc.) have been removed.
- appliances associated with the concept bed, parts of the concept bed or of the associated appliances are opened without explicit permission by the operating instructions (e.g. for cleaning).
- the instructions in this instruction manual have not been followed.
- the concept bed has suffered changes after repair operations performed by a third party unauthorized by Gharieni Group GmbH.

18. EC-Declaration Of Conformity

EC-Declaration of Conformity We, Gharieni Group GmbH Gutenbergstraße 40 47443 Moers / Germany		
hereby declare, in sole responsibility, that, due to its design and construction, the device named below complies with the relevant, fundamental safety and health requirements of the EU.		
(Type or model, name)		
	Lifting column beds Lina Select; MLX Quartz; MLX Limber; PediSpa series; MLR Wet; MLW Space; MLX iDome (MLX i³); MLR; MLX; RLL series; Ellipse; 601, E-Line, 701	2021
Relevant EU directives and harmonized standards used: 2006 / 42 / EU Machinery directive 2014 / 30 / EU Electromagnetic Compatibility Directive 2011 / 65 / EU ROHS Directive DIN EN ISO 12100 (2011) Safety of machinery - general principles for design Risk assessment and risk reduction		
Responsible for documents: Mohammad Abbassi Gutenbergstraße 40 47443 Moers / Germany	Manufacturer's signature: Sammy Gharieni, CEO 	Place and date: Moers, 20.05.2021

19. Status of edition

EDITION	ALTERATIONS (PAGES)	DATE
First edition	-	04/17/2015
Second edition	5	04/25/2016
Third edition	completely revised version	07/16/2021



NOTES

THE PROPERTY RIGHTS OF THIS INSTRUCTION MANUAL ARE RESERVED. ITS REPRODUCTION OR TRANSMISSION TO THIRD PARTIES IS FORBIDDEN WITHOUT THE AUTHORISATION OF THE OWNING COMPANY. THE POWER TO PROTECT ITS RIGHTS IS RESERVED AND OFFENDERS SHALL BE PROSECUTED.

DISTRIBUTION AND SHOWROOM	PRODUCTION, PICK-UP AND REPAIR
Gharieni Group GmbH Gutenbergstraße 40 47443 Moers / Germany	Gharieni Group GmbH Am Schürmannshütt 24 47441 Moers / Germany