

EST8050

Product Manual



EST8050

EST8050

Table of Contents

Part 1: Receiving and Inspection

Part 2: Specification

1. Product View
2. Description
3. Dimensions

Part 3: Assembly

1. Parts
2. Assembly steps

Part 4: Operation & Care

1. Operation
2. Upholstery Care
3. Metal Frame Care

Part 5: Warranty

Part 1: Receiving and Inspection



1. Before unpacking, please check the condition of the outer box. Please check whether the outer box is damp, damaged, or deformed. If so, please report to the relevant sales staff. It is strongly recommended this item is unpacked by two people.

2. Please be careful when unpacking. Do not use sharp tools which may damage the product.

3. Check whether the accessories are complete before beginning assembly.

Please read through this manual before assembling, installing, or using the product to ensure safe and correct use.

This product is designed for commercial use in hairdressing and beauty salons.

Do not use this product for purposes other than the practices and services typically offered in these places.

Please keep this manual in a safe place for your future reference.

EST8050

Part 2: Specification

1. Product View



2. Description

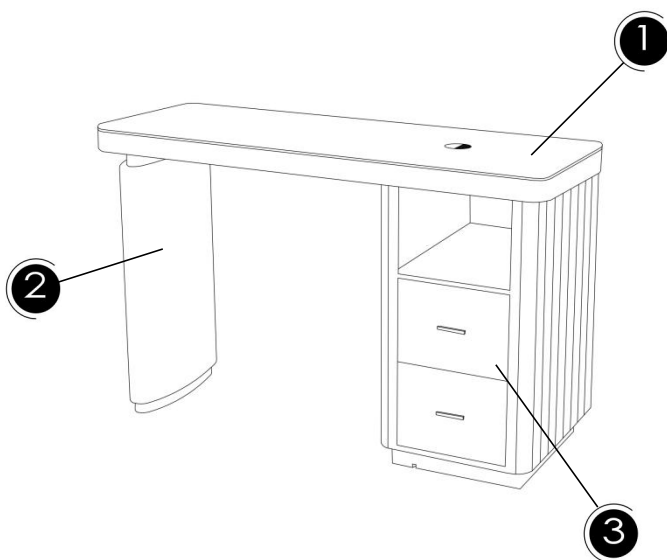

① Desktop

② Pillar

③ Cabinet

EST8050

3. Dimensions

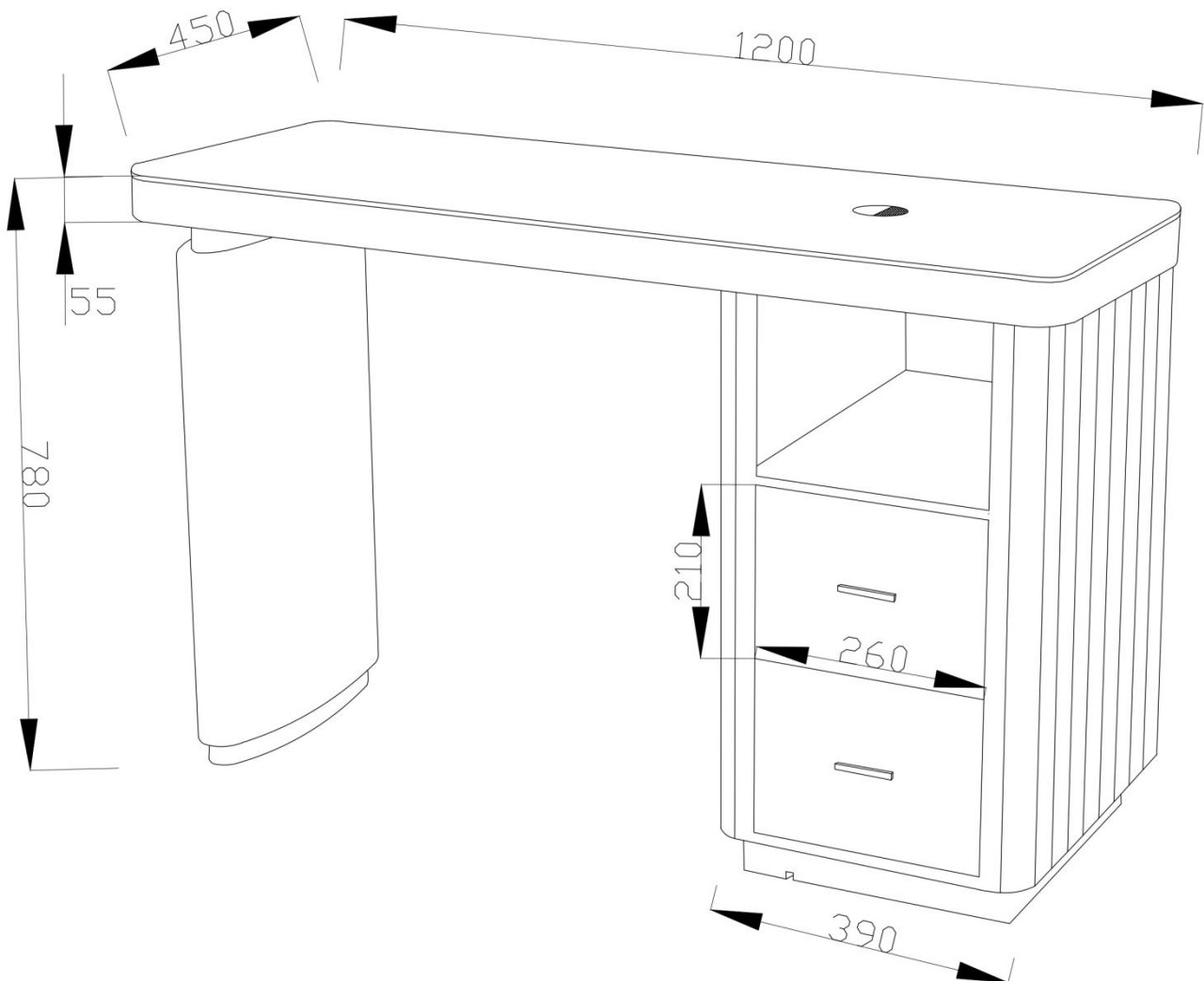

Desktop length: 1200mm/ Desktop width: 450mm
Desktop height: 55mm/ Table height: 780mm

EST8050

Part 3: Assembly

1. Parts

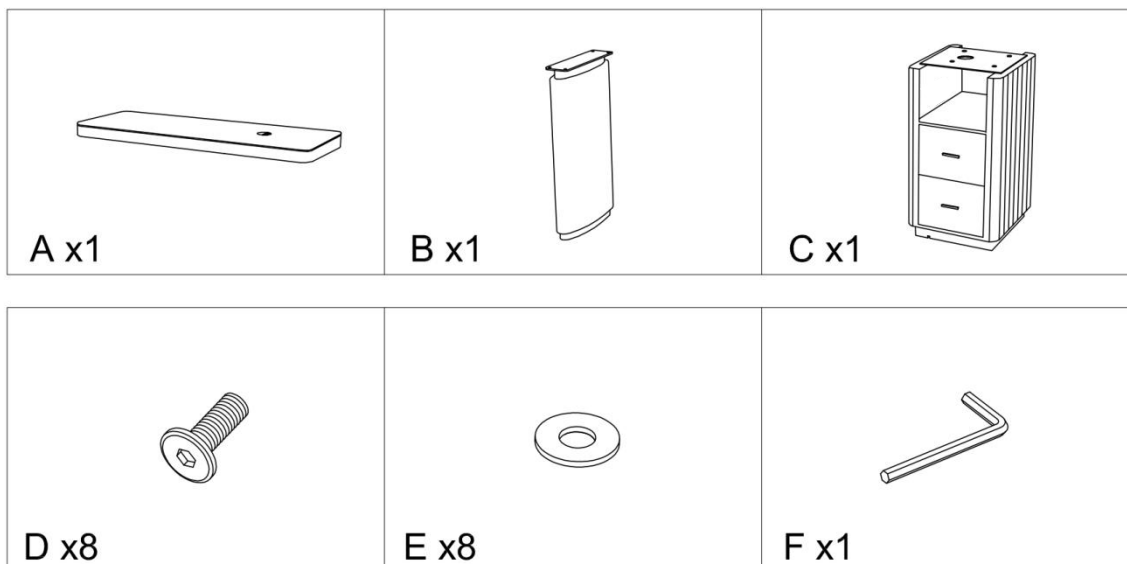

Spare Parts List:

- A. Desktop x 1
- B. Pillar x 1
- C. Cabinet x 1
- D. Screw x 8
- E. Gasket x 8
- F. Allen wrench x 1

2. Assembly steps

Steps: (Please refer to the picture below)

- 1) Align the holes of the cabinet and pillar with those of the desktop.
- 2) Put the gasket on the screw.
- 3) Align the screws with the holes and tighten with allen wrench.

EST8050

Step1

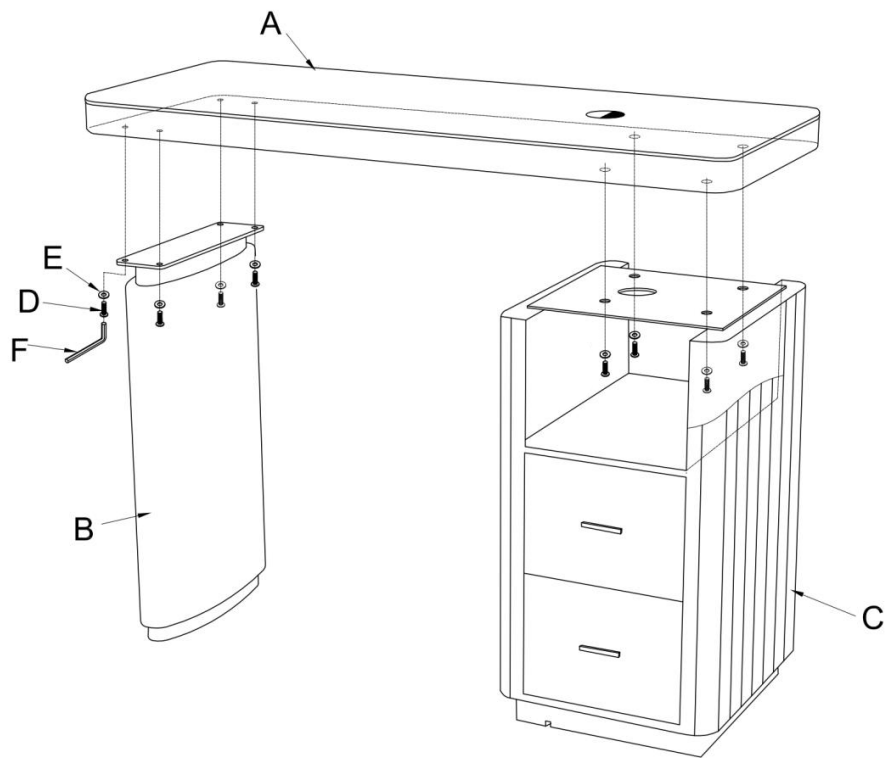

Step2



Part 4: Operation & Care

1. Operation

a) Assembly and construction:

Check all fastenings for any loosened screws etc. If found, please tighten appropriately. Continue to monitor during use.

b) In use :

1. Please lift the table when moving it, do not drag it.
2. When the table is unstable, try to achieve balance by adjusting the height of the foot pads under the table.
3. Ensure the table is placed on a flat secure surface and does not create trip hazards with cables or fixtures.
4. If any instability is noticed during use, discontinue use and ensure the table is checked by a suitably qualified person.
5. Avoid direct sunlight or heat sources.

2. Upholstery Care

1. Clean using a damp cloth and always dry after cleaning.
2. For stubborn dirt use mild detergent and wipe clean with water, afterwards, and dry.
3. Do not use any strong solvents on the upholstery such as alcohol or acetone.
4. Do not use abrasives of any kind.
5. Do not use brushes or scouring products.

EST8050

3. Metal Frame Care

Best practice includes:

1. Wear clean gloves.
2. Avoid contact with strong and abrasive floor cleaners.
3. When cleaning nearby surfaces, protect the frame by covering with plastic.
4. Do not allow corrosive materials to contact the frame. Keeping stainless steel products clean and free of salt or other corrosive elements

Never use the following products to clean stainless steel:

1. Oven cleaners
2. Chloride bleach
3. All-purpose cleaners
4. Any cleaner containing chloride
5. Steel wool or other abrasive scrubbing pads

Cleaning:

1. Use a mild detergent with warm water and a clean, soft cloth.
2. Use clean water. Gritty, dirty or excessively hard water can leave spots or brownish stains.
3. Wipe down with a clean sponge or cloth.
4. Use clean rinsing water to avoid water marks.
5. Dry with a clean dry cloth or an air blower.

EST8050

Part 5: Warranty

This product is guaranteed against mechanical defects for 12 months from date of purchase. During this guarantee period Ellisons will repair or replace the product free of charge provided the fault was not caused by misuse or improper handling, negligence, normal wear and tear, accidental damage or by any modifications made by the purchaser. Faulty products should be returned, see Ellisons website for returns policy. Returns damaged by poor packaging are the responsibility of the purchaser. If returning under this guarantee, you will be required to enclose proof and date of purchase. Please quote model number and batch number of the product in all correspondence. This guarantee does not affect your statutory rights.