



Instruction Manual

Treatment Table 601

STANDARD



Gharieni Group GmbH
Gutenbergstraße 40
47443 Moers / Germany

➤ Phone:	+49 (0)2841/88300-0
➤ Fax:	+49 (0)2841/88300-999
➤ Sales department:	+49 (0)2841/88300-300
➤ E-mail:	service@gharieni.com
➤ Web:	www.gharieni.com

Preface

Dear customer,

we would like to take this opportunity to thank you for purchasing our quality product and for the trust you have placed in us.

Please read this instruction manual before using the 601 for the first time.

Reading the complete instruction manual is essential for the proper and safe use of the 601 and will help you to operate the appliance to your complete satisfaction.

Our 601 is very robust and has a long lifespan when used properly.

Read all instructions very carefully and operate the 601 exclusively in accordance with the intended use as described in this instruction manual.

This is the best to ensure safe usage of the 601, and that improper use is avoided. Lack of knowledge on how to properly use the 601 could result in problems for the customer and breakage of the 601.

Always keep the instruction manual within easy reach of the 601.

THIS INSTRUCTION MANUAL MUST ALWAYS BE ACCESSIBLE TO ANY PERSON OPERATING THE 601. MAKE SURE THAT THE INSTRUCTION MANUAL HAS BEEN READ AND UNDERSTOOD BEFORE OPERATING THE TREATMENT TABLE.

⚠️WARNING! Non-compliance with the instructions in this manual endangers the operator's and customer's health and life and / or can damage the 601 and will render the warranty ineffective.

Index

1. Important safety information.....	5
1.1 Abbreviations	5
1.2 Signal words	6
1.3 Safety instructions.....	6
2. Intended Use	10
3. Scope of delivery	11
4. Preliminary remarks	11
5. Delivery and unpacking	12
5.1 Delivery.....	12
5.2 Unpacking.....	13
6. Assembly and transport	14
6.1 Assembly.....	14
6.2 Transport	15
6.3 Space requirements.....	18
7. Rating plate.....	19
8. QR-Code.....	20
9. Upholstery	24
10. Operation	25
10.1 Characteristics	25
10.2 Model versions	26
10.2.1 601 / upholstery widths: Small, MediumSmall, Medium	27
10.3 Before first use	27
10.4 View	28
10.5 Gas springs.....	30
10.6 Headrest	31
10.6.1 Headrest versions	34
10.6.2 Installing the U-shaped headrest	35
10.7 Armrests	36
10.7.1 Pneumatically adjustable armrests	36
10.7.2 Additional locking mechanism of the armrests.....	37
10.8 Arm supports.....	38
10.9 Legrest	39

10.10 Extendable footrests	39
10.11 Backrest	40
11. Electrical adjustments	40
11.1 Hand control	40
11.2 Adjustment of the working height	44
11.3 Adjustment of the backrest	44
11.4 Adjustment of the inclination of the seat area	45
11.5 Adjustment of the legrest	45
11.6 Locking function / locking button of the hand control	45
11.7 Memory functions of the hand control	47
12. Foot control with Bluetooth (optional equipment)	48
12.1 LED module	51
13. Heating system (optional equipment)	52
13.1 Operation	54
14. Reset	56
15. Malfunctions (causes and troubleshooting)	58
15.1. Repair	59
16. Cleaning and Care	60
16.1 Cleaning the PU upholstery	61
16.2 Cleaning and care of the Ferrari Stamskin	61
16.3 Cleaning the housing and the fittings	61
17. Optional equipment / optional accessories	62
17.1 Headrests	62
17.1.1 Standard headrest	62
17.1.2 Dual headrest	62
17.1.3 U-shaped headrest	63
17.2 Foot control	64
17.3 Castors	64
17.4 Mount for (magnifying) lamps	65
17.5 LED magnifying lamp „Circle“	65
17.6 Manicure bowl	66
17.7 Sheet metal for the headrest (privacy screen)	66
17.8 Paper roll incl. holder	67
17.9 Gel pad for nose slits	67
17.10 Nose slit cloths (disposable cloths)	68

17.11 Neckrest "Dentalax"	69
17.12 Protective covers	69
17.12.1 Terry cloth covers	69
17.12.2 Protective covers made of polyurethane (PU)	70
17.12.3 Foot protective cover	71
18. Upholstery care and cleaning agents	72
18.1 mikrozyd [®] sensitive (alcohol-free)	72
18.2 Skai cleaner	74
19. Conditions of transport, storage, and operation	75
19.1 Transport (with / without castors)	75
19.2 Ambient conditions for storage and transport	75
19.3 Ambient conditions for operation	75
20. Technical Data	76
20.1 Treatment table 601	76
20.2 Drives	77
20.3 Heating system	77
21. Disposal	78
22. Warranty	79
22.1 Exclusions from warranty	79
23. EC-Declaration of Conformity	80
24. Status of Edition	81



Do not dispose of the 601 together with your household waste.
The treatment table must only be disposed of via a collection point for reusable electrical and electronic equipment. Do not remove the symbols / stickers from the 601.

1. Important safety information

You must always observe basic safety precautions, including the following, when operating electrical products, especially when children are nearby:

READ THE COMPLETE SAFETY INFORMATION AND SAFETY INSTRUCTIONS ON THE FOLLOWING PAGES BEFORE USING THE 601 FOR THE FIRST TIME.

- **All information contained therein serves the safety of the operator. If you ignore the safety instructions, you endanger not only your own health and life but also the health and life of your customers.**

MAKE SURE THAT ALL PERSONS WORKING WITH THE GHARIENI TREATMENT TABLE 601 HAVE READ THE COMPLETE OPERATING INSTRUCTIONS AND HAVE UNDERSTOOD ALL INFORMATION AND INSTRUCTIONS CONTAINED THEREIN.

- This instruction manual is an integral part of the product and must be kept in a safe place for possible reference throughout the service life of the appliance. Copies of this instruction manual are available upon request.
- Gharieni Group GmbH is not responsible for any damage caused directly or indirectly to people, animals, or property due to non-observance or non-compliance with the instructions contained in this manual.
- Before you dispose of a treatment table, **render it inoperative.** This means that you should always pull the power plug and cut the power supply cable on the treatment table. Dispose of it directly with the power plug.

★ **Keep this instruction manual at hand for when needed. Follow all instructions thoroughly to avoid accidents or damage to the 601.**

1.1 Abbreviations

	➤ OPERATION INSTRUCTION / TIP
---	-------------------------------

1.2 Signal words

⚠ DANGER! indicates a hazardous situation which, if ignored, will result in death or serious injury.

⚠ CAUTION! indicates a hazardous situation which, if not avoided, may result in minor or moderate injury.

⚠ WARNING! indicates a hazardous situation which, if ignored, could result in death or serious injury.

NOTICE! indicates a hazardous situation which, if not avoided, may result in possible damage to the treatment table.

1.3 Safety instructions

⚠ DANGER!

To reduce risk of electrocution:

1. Non-compliance with the instructions in this manual endangers the operator's and customer's health and life and / or can damage the 601.
2. All electrical work to connect the 601 to the power supply must be carried out by a qualified professional. Do not modify the power supply. The connection must be carried out in accordance with the current local and legal regulations.
3. The mains voltage and the mains frequency **must** correspond to the values indicated on the rating plate.
4. Do not make any changes or manipulations to the 601 and / or its power supply (mains cable, mains plug). In case of unauthorised changes or manipulations, **any** warranty of the Gharieni Group GmbH is excluded.
5. **Do not connect** the 601 to the power supply if the 601 itself or the power cable or the power plug are visibly damaged.
6. The power cable must not be under the 601 except Gharieni Group GmbH expressly allows it. **RISK OF ELECTRIC SHOCK!**
7. Never roll the 601 over the power cable; otherwise you can permanently damage the power cable.
8. The power cable must not be located under the adjustable stands or under the optional castors of the 601. Otherwise they can crush the power cable and cause permanent damage. **RISK OF ELECTRIC SHOCK!**

9. Never try to repair the 601 yourself. If the 601 does not operate properly, please contact our customer service or your dealer. Original spare parts should be used only.
10. If repair or replacement of the power supply cable and / or the power supply plug is necessary, always commission a qualified specialist (electrical engineer) or a customer service authorized by Gharieni Group GmbH. Never repair or replace them yourself. RISK OF ELECTRIC SHOCK!
11. Always disconnect the 601 from the power supply if you are not going to use the treatment table for a long period of time.
12. Always disconnect the 601 from the power supply before cleaning and / or maintenance. RISK OF ELECTRIC SHOCK!
13. Never use the power cable to pull the power plug. Always pull the power plug itself to disconnect the 601 from the power supply. RISK OF ELECTRIC SHOCK!
14. **Never** touch the power plug, the power switch, or other electrical components with wet or damp hands. RISK OF ELECTRIC SHOCK!
15. Do not place or store the SPL med close to a source of liquid, such as a bathtub, a shower, or a washbasin. There is danger that the 601 may meet splashed water. RISK OF ELECTRIC SHOCK!

 **WARNING!**

To reduce risk of burns, electrocution, fire, or injury to persons:

1. Use only a properly secured safety socket with the appropriate mains voltage. See technical data and rating plate.
2. **The electric components must not encounter water.** RISK OF ELECTRIC SHOCK!
3. Check all cables regularly and contact the customer service when any cable is in improper condition. RISK OF ELECTRIC SHOCK!
4. Make sure that the power cable is not damaged when the treatment table is moved. Do not step on the power cable. Do not stretch the power cable.
5. Always ensure that the power cable is not bent or squeezed during installation.
6. Do not use any extension cables, multiple sockets, or adapters. FIRE HAZARD!
7. Never open the housing of the electrical control panels. RISK OF ELECTRIC SHOCK!
8. No liquids may enter the electrical control panels. RISK OF ELECTRIC SHOCK!

9. Never use water or other liquids for treatment or pour water or other liquids over, onto or into the 601! If water or liquids are spilled across or on the treatment table, immediately pull out the power supply plug and dry the 601 thoroughly. RISK OF ELECTRIC SHOCK!
10. Never immerse parts of the 601 in water or other liquids! When cleaning the 601, make sure that water never gets into the treatment table itself or its housing. RISK OF ELECTRIC SHOCK!
11. If the treatment table is equipped with the heating system (optional equipment), the cables are located between the upholstery and the underframe. **The upholstery may only be removed by persons authorized by Gharieni Group GmbH.**
12. If your 601 is equipped with the optionally available heating system, do not place heavy blankets, clothing or similar on the upholstery while the heating system is switched on. RISK OF DAMAGE! RISK OF BURNS!
13. **People with acute pain, venous disorders, low blood pressure, inflammatory processes and other medical conditions that make heat applications or this form of client positioning questionable must always consult a doctor before use.**
14. **Never use the 601 on people who are under the influence of alcohol or drugs.**
15. Only operate or store the 601 in a dry place.
16. Always keep the 601 under close observation when used by, on or near children and / or people with reduced physical, sensory, or mental capabilities or lack of experience and knowledge.
17. The 601 may only be used for its intended purpose, as described in this instruction manual. Do not use any accessories / devices that are not recommended by Gharieni Group GmbH.
18. Never operate the 601 if the power cable or plug is damaged, if the 601 is not working properly if it has been damaged or if it has become wet. Take the 601 to a service centre authorized by Gharieni Group GmbH for inspection or repair.
19. In case of defects or malfunctions of the treatment table, contact customer service **immediately**. Use of the treatment table **must** be discontinued until the problem has been solved to avoid further damage to property and persons.
20. Regularly remove any dust build-up from the mains plug, the safety socket, and all electrical plug connections, e.g. with a commercially available vacuum cleaner. RISK OF FIRE!
21. Keep the power cable away from heated surfaces.
22. Never put or insert objects of any kind into any opening (s) of the 601.
23. **Never** use the 601 outdoors.

24. Make sure that the 601 is only operated by authorized persons.
25. Make sure that the 601 is on an even surface when in use.
26. Never put any objects containers with liquids of any kind on the 601. This could damage the treatment table and the material.
RISK OF ELECTRIC SHOCK! RISK OF DAMAGE!
27. All repair or maintenance work may only be carried out by personnel authorized by the Gharieni Group GmbH.
RISK OF ELECTRIC SHOCK! FIRE HAZARD!
28. Never use a steam cleaner for cleaning. RISK OF ELECTRIC SHOCK!
29. Do not support or stand on any area of the bed surface or the support structure / base of the 601. Do not exert any strong physical force on the parts mentioned. Otherwise you can permanently damage the support structure / base of the treatment table.
RISK OF TIPPING! BREACH DANGER! RISK OF INJURY!
30. When adjusting the bed surface, there must be no people, parts of the body, animals or objects between the base and the bed surface.
RISK OF CRUSHING!
31. When setting the treatment position, make sure that there are no body parts or objects between the bed components. RISK OF CRUSHING!
32. Do not use the base as a footrest. RISK OF DAMAGE!
33. Make sure that the 601 is always firmly on its adjustable stands or that the castors are always locked. If the 601 is standing solely on the movable castors, there is a RISK OF ROLLING AWAY!
34. Do not move the 601 on its castors while there are people or loads on the 601. Otherwise you will damage the construction / substructure of the 601 and its castors. RISK OF INJURY! RISK OF DAMAGE!
35. The 601 must never (neither with nor without castors) be used to transport people or heavy loads. RISK OF INJURY! RISK OF DAMAGE!
36. While unpacking, the packaging materials should be kept away from children, pets, or persons with reduced mental capabilities.
RISK OF INJURY! CHOKING HAZARD!
37. Always keep children and animals out of reach of the 601.
38. Children should **never** play with the 601 or any of its components.
39. The 601 must not be used by persons with reduced physical, sensory, or mental capabilities or a lack of experience and / or knowledge unless they are supervised or instructed in the safe use of the 601 and understand the hazards involved.

NOTICE!

1. **Only lift the 601 vertically off the pallet.** Non-compliance with this instruction could seriously damage the stands / castors of the 601.
2. For safety reasons, the treatment table only moves if you press one of the buttons on the hand control or the optional foot control. When released, the movement is stopped immediately.
3. Never support, stand, or kneel on any part of the bed surface. Do not exert any strong physical force on the treatment table's surface. Otherwise you can permanently damage the upholstery of the 601. **RISK OF DAMAGE!**
4. Do not lean against the arm supports or the headrest! Never stand, sit, or kneel on the arm supports or the headrest. **RISK OF DAMAGE!**
5. The 601 is equipped with a locking function to protect against unauthorized use. The drive system locks automatically after 30 minutes of non-operation. The heating cycle currently in process is not affected by this. Manual locking also does not affect the heating cycle currently in process and has no effect on the operation of the heating system.
6. The maximum load capacity of the armrests is 25 kg.
7. The rating plate must never be made illegible or removed!
Non-compliance will result in the exclusion of the warranty!

READ THIS INSTRUCTION MANUAL THOROUGHLY
AND KEEP IT IN A SAFE PLACE FOR FUTURE REFERENCE.

2. Intended Use

- i** Read these instructions thoroughly.
Only operate the treatment table in the intended use as described to protect your customers and yourself from danger.
- ❖ The 601 is a treatment table and **no** medical device.
- ❖ The 601 is a multi-functional treatment table which e.g. can be used for cosmetic applications, facial treatments, or all types of massages in dry environments. **Any other use is not permitted and affects your warranty claims.**
- ❖ The 601 is **only** intended for use in closed rooms with defined ambient conditions. See chapter 19. CONDITIONS OF TRANSPORT, STORAGE AND OPERATION.

★ **No liability for personal injury or material damage will be accepted if these instructions are not followed.**

3. Scope of delivery

- 1 TREATMENT TABLE 601 in the desired design and equipment
- 1 HAND CONTROL
- 1 INSTRUCTION MANUAL

i If you have ordered additional optional accessories / further optional equipment for your treatment table at the time of purchase, this is also included in the scope of delivery.

4. Preliminary remarks

- ❖ The Gharieni treatment table 601 is subject to the highest safety and quality standards.
- ❖ Before first use, please check that all components are present and that they are not visibly damaged.
- ❖ Make sure that the socket for the treatment table is properly grounded and has the correct mains voltage and mains frequency, see rating plate.



Before setting up, make sure that there is enough space for the 601 so that it does not meet anything even when it is fully extended.

5. Delivery and unpacking

5.1 Delivery

- i** The 601 is delivered on a pallet in a cardboard box (s. fig. below).
The 601 is completely horizontal and the upholstery is already in place.
- i** The legrest is in the lowest position.
- i** The armrests are swiveled 180° and pushed completely towards the seat.
- i** The extendable footrests are in the box under the head end of the 601, on the pallet.
- i** The optionally available metal sheet as a privacy screen for treatments in the prone position is also in the box, the corresponding rail must be attached to the underside of the headrest using the screws provided. If you do not need the sheet, you can stow it using a second rail on the legrest.



Fig. similar, fig. serves as an example only.

DELIVERY BY GHARIENI GROUP GMBH:

If the delivery is handled by Gharieni Group GmbH, the delivery driver will help to set up the 601 and will also dispose of the packaging material and the pallet.

DELIVERY BY A SHIPPING COMPANY:

If a shipping company handles the delivery, usually the 601 will only be delivered (no help with the installation of the 601). In this case, you must dispose of the packaging material and the pallet on your own.

5.2 Unpacking

⚠ WARNING! When unpacking, make sure that the components of the packaging are out of reach of children and animals. RISK OF SUFFOCATION!

- i** The 601 is delivered on a pallet in a box (s. fig.).
- i** The legrest is in the lowest position.
- i** The armrests are swiveled 180° and pushed completely towards the seat.
- i** The extendable footrests are in the box under the head end of the 601, on the pallet.
- i** The optionally available metal sheet as a privacy screen for treatments in the prone position is also in the box, the corresponding rail must be attached to the underside of the headrest using the screws provided.

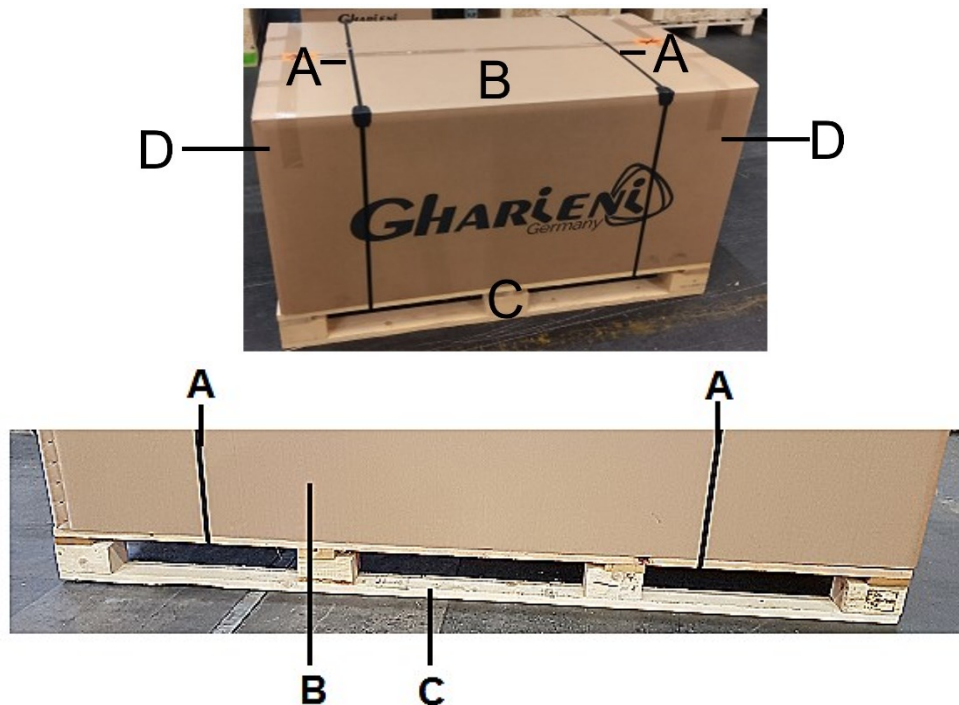

Fig. similar, fig. serves as an example only.

A	PACKAGING STRAPS
B	UPPER BOX
C	PALLET
D	SHORT SIDE OF THE BOX

1. Cut the packaging straps **(A)** with scissors and remove them.
2. **Do NOT** open the upper cardboard box **(B)**, but carefully lift it as a whole and vertically from the 601 and the pallet **(C)**. You will need two people for this (one person each on the short sides of the box) **(D)**.
3. Dispose of the cardboard box properly.
4. You can now lift the 601 off the pallet (it is imperative that you follow the instructions in chapter 6.2 TRANSPORT).



6. Assembly and transport

6.1 Assembly

In case of delivery by Gharieni Group GmbH, the delivery driver will help to set up the 601 and will perform the assembly of the parts disassembled for shipment and positioning of the corresponding parts to make the 601 ready for use.

If the 601 is delivered by a shipping company, you must assemble these parts yourself (s. chapter 5.2 UNPACKING).

The armrests are swiveled 180° and pushed completely towards the seat.

Loosen the knurled screw on the underside of the armrests, pull the armrests out slightly and now swivel the armrests upwards.

Be sure to tighten the knurled screw again.

Before raising the legrest completely, please adjust the height of the 601 first to avoid a collision of the legrest with the pallet.

Now slide the extendable footrests into the corresponding mountings in the legrest of the 601; the footrests are in the box under the head end, on the pallet.

If you have ordered the optional metal sheet as a privacy screen for treatments in the prone position, this is in the same box.

The corresponding rail must be attached to the underside of the headrest using the screws provided. If you do not need the sheet, you can stow it using a second rail on the legrest.

- i** Before setting up the 601, make sure that there is enough space for the 601 so that it does not meet anything even when it is fully extended.

⚠ WARNING! If the treatment table is equipped with the heating system,¹ the cables are located between the upholstery and the underframe. **The upholstery may only be removed by persons authorized by the Gharieni Group GmbH.**

6.2 Transport

- i** Always consider the dimensions of the 601 when transporting. Transporting the 601 can sometimes be severely affected by unsuitable ambient. Such unsuitable ambient conditions are, e.g., narrow doors, narrow corners behind doors, narrow corridors, narrow stairways, spiral staircases etc. Weight of the 601 is at least approx. 120 kg; the length ranges from 180 cm to 200 cm and width including upholstery; this limits maneuverability of the 601.
- ❖ The best way to carry the bed is to lift it by the base only, one person at each corner of the base. Remove the transport lock (2 straps / if available) before putting the bed into operation.
 - ❖ Never lift the 601 by the seat / lying surface or the armrests during transport. Otherwise you can seriously damage the 601.
 - ❖ The 601 can be **carefully** moved or transported **on flat surfaces** using the castors. Do not use the castors on uneven surfaces.

NOTICE! Always secure the optional castors immediately by locking them. **RISK OF INJURY! RISK OF ROLLING AWAY!**

⚠ DANGER! Never roll the 601 over the power cable. Otherwise you can permanently damage the power cable.

⚠ DANGER! The power cable must not be under the adjustable stands or under the castors of the 601. Otherwise they can crush the power cable or cause permanent damage. **RISK OF ELECTRIC SHOCK!**

⚠ WARNING! Do not move the 601 on the castors while there are people or loads on the 601. Otherwise you will damage the construction or substructure of the 601 and the castors. **RISK OF INJURY! RISK OF DAMAGE**

¹ Optional accessory

⚠ WARNING! The 601 must never (neither with nor without castors) be used to transport people or heavy loads. RISK OF INJURY! RISK OF DAMAGE!

i **Before moving the 601**, roll up the power cable properly and store it so that it cannot be rolled over when moving the 601. Do not hold the castors in place until the 601 is in desired position and you have ensured that the power cable is not located under the 601 or under its stands or castors.

⚠ WARNING! RISK OF INJURY by pinching the toes / feet when moving the bed!

NOTICE! Make sure to lift the 601 vertically off the pallet. Non-compliance with this instruction may seriously damage the stands or castors of the 601. RISK OF DAMAGE!

NOTICE! The special pallet on which the 601 is delivered has several round cut-outs (s. fig. below). On delivery, the adjustable stands of the 601 are placed in the respective cut-outs to prevent the wellness bed from moving. **It is therefore essential that you lift the 601 vertically off the special pallet.** Non-compliance with these instructions can seriously damage the stands or the optional castors of the 601. RISK OF DAMAGE!



i Illustrations similar: all illustrations in this chapter serve as examples only.

NOTE! You need **4 persons** to lift the 601 off the pallet.

1. To lift the 601 off the pallet, it must first be raised slightly so that the upholstery of the legrest does not collide with the edge of the pallet.
To do this, first connect it to a suitable connection socket. Then press the corresponding button of the hand control and keep it pressed. The hand control is located on the side of a suspension device (**button T1**, see figure in chapter 11.1 HAND CONTROL).



2. You must also bring the backrest into an upright position before lifting the 601. To do this, press the corresponding button on the hand control and keep it pressed (**button T2**, see figure in chapter 11.1 HAND CONTROL).
3. **Then pull the power supply plug !**
4. Lift the 601 with one person at each corner of the base by hand **simultaneously**. You need four people to do this.

NOTICE! You must always lift the 601 with one person simultaneously at each corner of the base, otherwise you can seriously damage the bed.
RISK OF DAMAGE!

5. You also need **four persons** to carry the 601 to the location you want.
 6. Be sure to lift the 601 **vertically** off the pallet. Otherwise you will damage the stands or castors.
 7. Carry the 601 **by the base only**. Otherwise you can irreparably damage the 601.
 8. If the floor is not completely level, you must ensure the stability of the 601 by adjusting the four stands (B), (see figure).
- ❖ The treatment table is fully operational in just a few simple steps. It can be flexibly adapted to any body size. Depending on the purpose, you can set the desired position electrically in a very short time and then concentrate entirely on your customers.

ADJUSTABLE STANDS OF THE 601

- ❖ Use the adjustable stands to properly align the 601. The 601 must be in a stable and level position for proper operation. In order that the 601 does not wobble, the 4 stands must stand firmly on the floor.

NOTICE! If the floor is not completely level, the stability may have to be adjusted to the floor by using the adjustable stands.

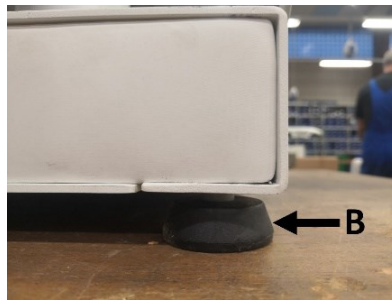

B | ADJUSTABLE STAND

i optionally available: lockable castors

- You can also buy the castors after purchase.
- When using the castors, the working height is increased by 5.5 cm.

For detailed information, please contact Gharieni customer service.

- see also chapter 17.3 CASTORS

6.3 Space requirements

- i** Before setting up, make sure that there is enough space for the 601 so that it does not meet anything even when it is fully extended.

7. Rating plate

- ★ The rating plate is located **at the head end** of the 601: on the wood panel underneath the backrest.
1. To gain access to the rating plate, you must place the backrest in an upright position (see figure below / **button T2** of the hand control, see fig. in chapter 11.1 HAND CONTROL).



2. The rating plate is located on the wooden covering (see figure).



A

RATING PLATE

- ★ The first item on the rating plate is the serial number.
- i** **The rating plate must never be removed or made illegible! Non-compliance will invalidate the warranty!**

8. QR-Code



In case of service, you can scan the QR-Code using the OCR scan function of a suitable device (e.g. a smartphone). A form will then open via the Internet browser of your device, which already automatically contains the serial number of your 601. Please describe your problem there and enter your data. You can attach a file from your device memory or take a photo with your device and attach it. To do this, tap on the "Select file" button. A window with options will then open. The appearance of this window may differ from the illustration, depending on your device and operating system. After you have confirmed that you have read our data protection guidelines by marking the box at the end of the form, the form with all the entries you have made is immediately sent to our customer service department by clicking on "Send".

❖ The QR-Code is located on the **head side** of the 601, next to the rating plate: on the wooden covering below the backrest.

i To gain access to the QR-Code, you must place the backrest in an upright position (see the figure in chapter 7. RATING PLATE / button **T 2** of the hand control) and keep it pressed, (s. fig. in chapter 11.1 HAND CONTROL).

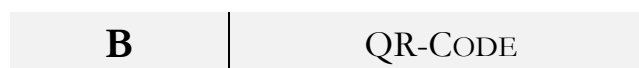

(Figure similar, position might differ)

Serial number (Complete as written on nameplate) /
Seriennummer (Komplett wie im Typenschild) /
Numéro de série (Complet comme inscrit sur la plaque d'identification)

KoM4-3A-M1-SUPERSOFT-SM-RAL9007-0530

Please describe the issue* (Required Field) /
Bitte schildern Sie das Problem * (Pflichtfeld) /
Veuillez s'il vous plait décrire le problème* (Champ obligatoire)

Add file: / Datei hinzufügen: / Ajoutez un fichier:

Datei auswählen Keine ausgewählt

Your address / Ihre Adresse / Votre adresse

First and last name* (Required Field) /
Vor- und Zuname * (Pflichtfeld) /
Prénom et nom* (Champ obligatoire)

Company / Firma / Entreprise

Street adress /
Strasse und Hausnummer /
Rue et numéro de rue

ZIP Code* (Required Field) /
Postleitzahl* (Pflichtfeld) /

Figure shows form that opens in the Internet browser of the device after the QR code is scanned.

Code postal* (Champ obligatoire)

City* (Required Field) /
Stadt* (Pflichtfeld) /
Ville* (Champ obligatoire)

E-Mail-Adress* (Required Field) /
E-Mail-Adresse* (Pflichtfeld) /
Votre adresse e-mail* (Champ obligatoire)

Phone number* (Required Field) /
Telefonnummer* (Pflichtfeld) /
Téléphone* (Champ obligatoire)

I read the privacy policy of the Gharieni Group.
Ich habe die [Datenschutzrichtlinien](#) der Gharieni Group gelesen.< /br> J'ai lu la [protection des données](#) du Groupe Gharieni.

SEND

Figure shows form that opens in the Internet browser of the device after the QR code is scanned.

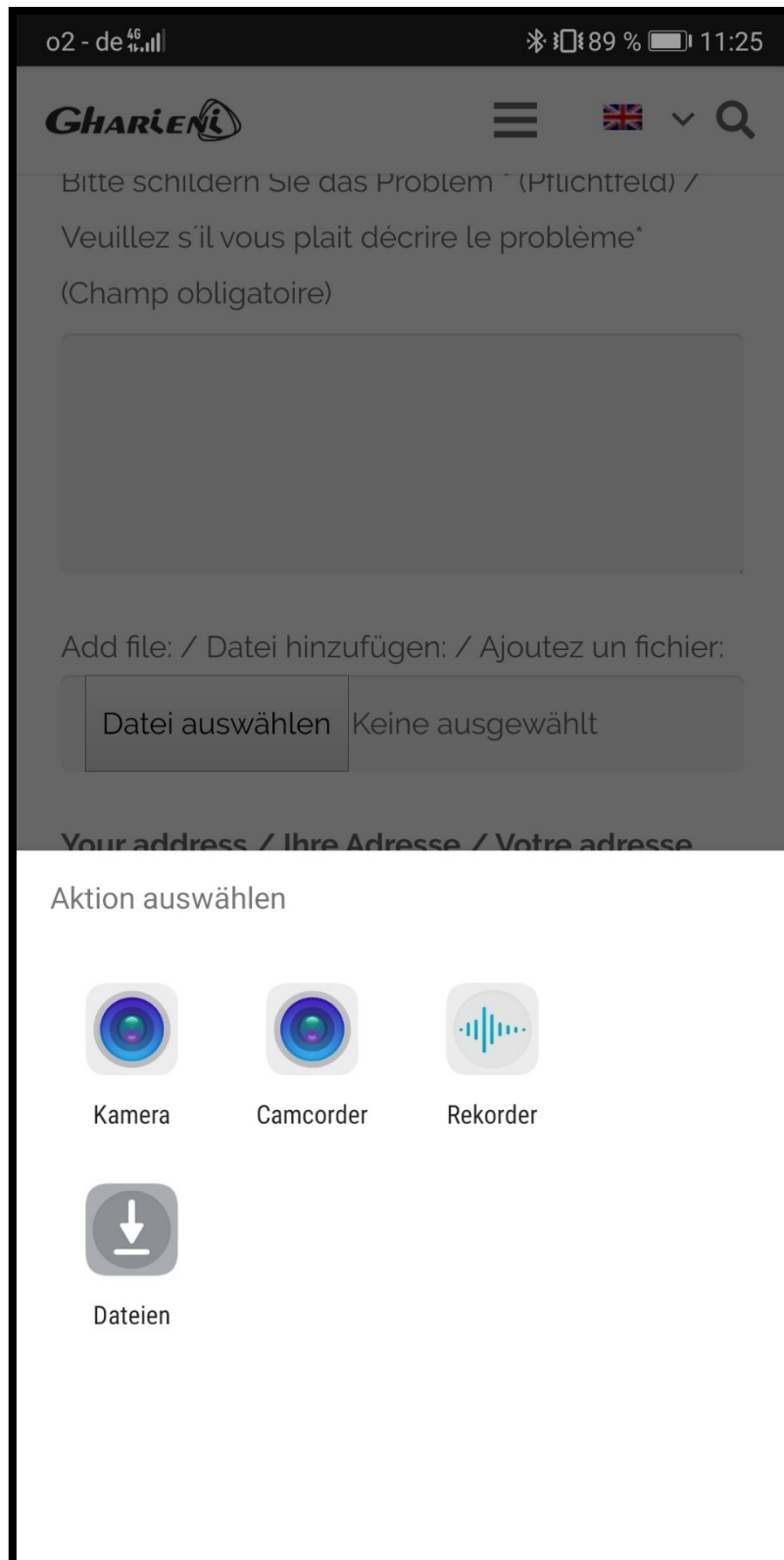

*Figure similar: option window for adding a file.
Appearance may vary depending on the device and operating system.*

9. Upholstery

- ❖ The 601 is available in two upholstery variants (standard and soft / see below).
- ❖ The upholstery of the 601 is made of polyurethane (PU), artificial leather or Ferrari Stamskin and is delivered in the colors white or chocolate as standard.
- ❖ Additional colors from our color collection for PU, artificial leather or Ferrari Stamskin upholstery are optionally available for an additional charge.

STANDARD UPHOLSTERY MADE OF POLYURETHANE (PU), ARTIFICIAL LEATHER OR FERRARI STAMSKIN:

- ❖ The **STANDARD UPHOLSTERY** consists of a soft, comfortable, and high quality one-piece cushion (see figure below).
- ❖ The inner material of the upholstery is made of high quality foam.
- ❖ The outer material is made of **polyurethane (PU)** or Ferrari Stamskin and is available in different colors from our color collection for PU, artificial leather, or Ferrari Stamskin upholstery.
- ❖ This material (PU) is elastic and easy to care for. It is impermeable to water, impermeable to oil and washable up to 90 °C.



Illustration similar: color and design may vary depending on the model.

SOFT UPHOLSTERY MADE OF POLYURETHANE (PU), ARTIFICIAL LEATHER OR FERRARI STAMSKIN:

- ❖ The **SOFT UPHOLSTERY** consists of a comfortable, ergonomic, and high quality one-piece cushion (see figure below).
- ❖ The soft upholstery is shaped to fit the body.
- ❖ The inner material of the upholstery is made of high quality foam.
- ❖ The outer material is made of **polyurethane (PU)**, artificial leather or Ferrari Stamskin and is available in different colors from our color collection for PU, artificial leather, or Ferrari Stamskin upholstery.
- ❖ This material (PU) is elastic and easy to care for. It is impermeable to water, impermeable to oil and washable up to 90 °C.



Illustration similar: color and design may vary depending on the model.

NOTICE! Follow our cleaning and care instructions for PU, artificial leather, and Ferrari Stamskin! If you would like to use other cleaning agents, be sure to contact our customer service before use. **RISK OF DAMAGE!**

10. Operation

⚠ WARNING! Never sit on the headrest or armrests.

⚠ WARNING! Regardless of the bed's surface setting, do not exert any physical force on the above-mentioned components. Non-compliance with these instructions can permanently damage the support structure of the 601. **RISK OF TIPPING! RISK OF BREAKING! RISK OF INJURY!**

10.1 Characteristics

- ❖ The 601 is a versatile treatment table that you can use e.g. cosmetic applications or full body massages in dry rooms.
- ❖ The 601 is available in two upholstery variants (STANDARD and SOFT); see chapter 9. UPHOLSTERY.
- ❖ The entry height due to the SOFT and thicker upholstery is approx. +5 cm compared to the STANDARD upholstery.
- ❖ The 601 is also available in various upholstery widths (SMALL, MEDIUMSMALL, MEDIUM/ see chapter 10.2 MODEL VARIANTS).
- ❖ The Gharieni 601 is a treatment table with two lifting columns and two actuators (see chapter 10.2 MODEL VARIANTS) intended to adjust the table using a hand control or an optional foot control.
- ❖ Working height, backrest, inclination of the seat area and legrest are electrically adjustable. [The adjustment of the working height is achieved by synchronous movement of the lifting columns (front and rear lifting columns move), the adjustment of the seat inclination is achieved by asynchronous movement of the lifting columns (only the front lifting column moves), see chapter 11. ELECTRICAL ADJUSTMENTS.

- ❖ Frequently used treatment positions can be adjusted, stored, and recalled by two individual memory positions using the hand control or optional foot control (see chapter 11.7 MEMORY FUNCTIONS OF THE HAND CONTROL and chapter 12. FOOT CONTROL).
- ❖ The 601 is equipped with four pre-set positions which you can adjust using buttons P1 to P4.
- ❖ The optional armrests are pneumatically adjustable and swiveling; s. chapter 10.7.1 PNEUMATICALLY ADJUSTABLE ARMRESTS.
- ❖ The inclination of the headrest can be adjusted manually using a locking pin, the headrest is horizontally adjustable and completely removable using a rail (see chapter 10.6 HEADREST).
- ❖ In addition to the standard headrest, the 601 can be equipped with two other variants: the dual headrest with an exchangeable round or horn-shaped face support or the U-shaped headrest. (see chapter 17.1 HEADRESTS).
- ❖ The optional arm supports are extendable and can be rotated by 180°.
- ❖ When purchasing a 601, a hand control is always included as an adjustment control. Optionally, for an extra charge, a foot control can be purchased.
- ❖ The 601 is equipped with many adjustment options and can therefore be used for numerous applications.
- ❖ The maximum lifting capacity of the 601 is approx. 250 kg.
- ❖ The maximum load capacity of the treatment table's surface is approx. 300 kg.
- ❖ The maximum load capacity of the armrests is 25 kg.
- ❖ The maximum load capacity of the arm supports is 25 kg.

10.2 Model versions

- The treatment tables of the Gharieni 601 series are available in three different upholstery widths: SMALL 75 CM / MEDIUMSMALL 80 CM / MEDIUM 85 CM.
- ❖ The treatment tables of the Gharieni 601 series are equipped with two lifting columns and two actuators, with which you can adjust the treatment table using the hand control or the optional foot control.
- ❖ The **non-actuator-operated** areas (headrest / armrests) can be adjusted pneumatically or manually by operating a gas spring using a lever or manually using a knurled screw.
 - see also chapter 10.6 HEADREST
 - see also chapter 10.7 ARMRESTS
 - see also chapter 10.8 ARM SUPPORTS
 - see also chapter 11. ELECTRICAL ADJUSTMENTS.

10.2.1 601 / upholstery widths: Small, MediumSmall, Medium

601 (S / MS/ M) / 4 ACTUATORS	
2 lifting columns	<ul style="list-style-type: none">• electrical HEIGHT ADJUSTMENT• INCLINATION OF THE SEAT AREA adjustable through asynchronous running of the lifting columns
Actuator 2	BACKREST electrically adjustable.
Actuator 3	LEGREST electrically adjustable.

- The **pneumatically** adjustable arm supports can be lowered **and** swiveled.
- The armrests can be swiveled **and** pulled out manually.
- Using the hand control, two memory positions can be individually adjusted, stored, and recalled. In addition, four positions are permanently stored.

10.3 Before first use

- Before first use, make sure that all parts are present (see chapter 3. SCOPE OF DELIVERY) and that there is no visible damage.
- The dedicated safety socket must be grounded properly and must meet the proper voltage. See technical data and rating plate.
- ❏ Before setting up, make sure there is enough space for the 601.
- ❏ The space required to walls and objects is approx. 70 cm all around.
The 601 measures approx. 200 cm x approx. 85 cm.

10.4 View



Illustration similar: color and design may vary depending on the model.

1	<u>BASE</u>
2	<p><u>ARMRESTS:</u></p> <ul style="list-style-type: none"> ➤ pneumatically adjustable and swiveling ➤ see chapter 10.5 GAS SPRINGS and chapter 10.7.1 PNEUMATICALLY ADJUSTABLE ARM RESTS ➤ can also be locked (see chapter 10.7.2) - see # 12: additional locking mechanism of the armrests ➤ optionally available
3	<p><u>HEADREST:</u></p> <ul style="list-style-type: none"> ➤ inclination manually adjustable ➤ manually extendable ➤ completely removable ➤ with nose slit ➤ see chapter 10.6 HEADREST. ➤ optionally available; see chapter 17.1 HEADRESTS. ➤ In addition to the standard headrest, two further variants are available: dual headrest with changeable round or horn-shaped face cushion or U-shaped headrest.

4	<p><u>BACKREST:</u></p> <ul style="list-style-type: none"> ➤ electrically adjustable ➤ see chapter 10.11 BACKREST and chapter 11.3 ADJUSTMENT OF THE BACKREST.
5	<p><u>SEAT AREA:</u></p> <ul style="list-style-type: none"> ➤ thigh to knee area
6	<p><u>ARM SUPPORTS:</u></p> <ul style="list-style-type: none"> ➤ manually swiveling and extendable ➤ see chapter 10.8 ARM SUPPORTS ➤ optionally available ➤ Optionally available: holder for manicure bowl s. chapter 17.6 MANICURE BOWL
7	<p><u>HOLDERS FOR MANICURE BOWL</u> (on both arm supports):</p> <ul style="list-style-type: none"> ➤ The manicure bowl is available including a ring-shaped holder that fits into these holders; they are pre-installed at the arm supports. ➤ see chapter 17.6 MANICURE BOWL
8	<p><u>LEGREST:</u></p> <ul style="list-style-type: none"> ➤ electrically adjustable ➤ see chapter 10.9 LEGREST and chapter 11.5 ADJUSTMENT OF THE LEGREST.
9	<p><u>EXTENDABLE FOOTRESTS:</u></p> <ul style="list-style-type: none"> ➤ manually adjustable ➤ see chapter 10.10 EXTENDABLE FOOTRESTS
10	<p><u>ADJUSTABLE FEET / CASTORS OPTIONALLY AVAILABLE:</u></p> <ul style="list-style-type: none"> ➤ see chapter 6.2 TRANSPORT and chapter 17.3 CASTORS
11	<p><u>HAND CONTROL HOLDER:</u></p> <ul style="list-style-type: none"> ➤ on both sides ➤ see chapter 11.1 HAND CONTROL

12	<p><u>ADDITIONAL LOCKING MECHANISM OF THE ARMRESTS</u></p> <ul style="list-style-type: none"> ➤ see chapter 10.7.2
13	<p><u>MOUNT FOR LED MAGNIFYING LAMP</u> (on both sides of the bed, optional):</p> <ul style="list-style-type: none"> ➤ for LED magnifying lamp “Circle” (optionally available) ➤ extendable ➤ can be stowed under the legrest when not in use ➤ optionally available; see chapter 17.11 MOUNT FOR (MAGNIFYING) LAMPS
14	<p><u>HEAD END:</u></p> <ul style="list-style-type: none"> ➤ The rating plate is located at the head end under the backrest (on the wooden covering below the backrest). ➤ see chapter 7. RATING PLATE and chapter 8. QR-CODE.

10.5 Gas springs

- ❖ The armrests are adjusted with a gas spring (pneumatic).
- ❖ If you make an adjustment using the gas spring lever, you **only** need to operate the lever **when lowering** and press it down with your hand.
- ❖ To lift an armrest again, pull it upwards (**without operating the corresponding lever**).

10.6 Headrest

⚠ WARNING! Never exert physical force on the headrest, regardless of the treatment table's surface setting. Non-compliance with these instructions can permanently damage the support structure. **RISK OF TIPPING! RISK OF BREAKAGE! RISK OF INJURY!**

- i** Use the locking pin to adjust the headrest, which is located under the headrest. Pull the locking pin and adjust the headrest. Make sure that the locking pin audibly engages again after setting.
- i** The inclination angle of the headrest is manually adjustable in five preset levels (+ 10°, 0°, -10°, -20°, - 90°) (s. figures).
- i** The headrest can also be pulled out manually by a maximum of 7 cm and removed. The extension range of the headrest is limited to 7 cm via locking pin. To extend the headrest, loosen the knurled screw and pull out the headrest together with the mount as desired. Then tighten the knurled screw again. The locking pin is located on the backrest frame, below the locking pin for adjusting the inclination angle of the headrest (s. fig. 3).

NOTICE! Be sure to tighten the knurled screw again. Otherwise the headrest may fall out and damage the 601 and/or your customer may be injured! **RISK OF DAMAGE! RISK OF INJURY!**

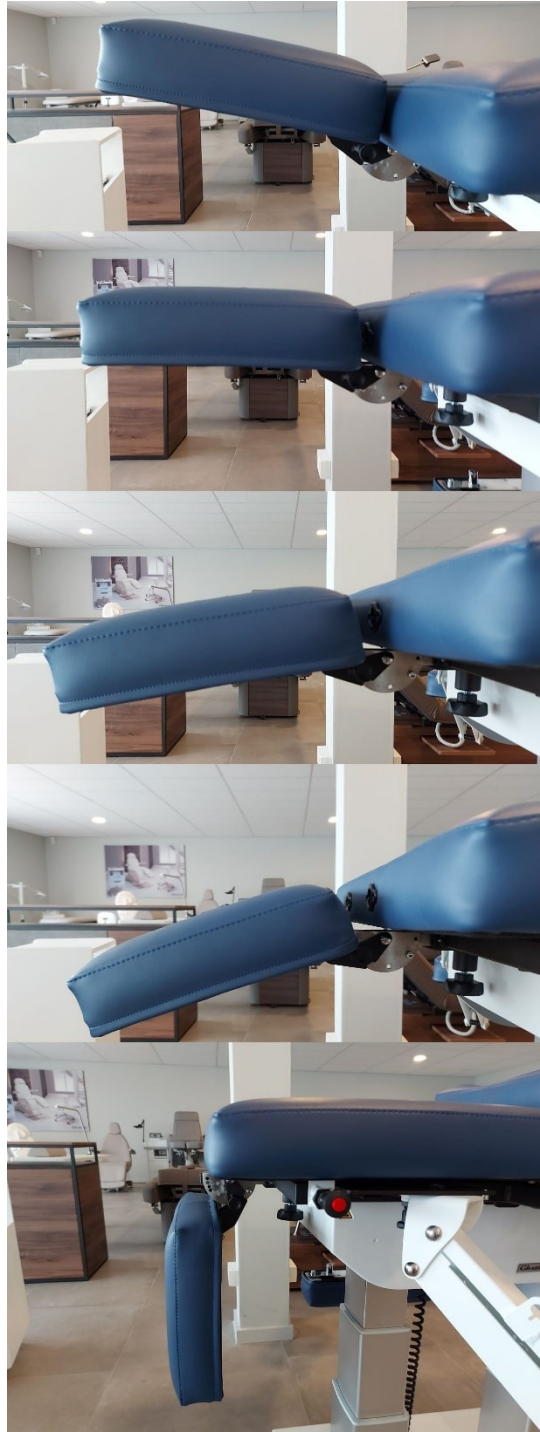

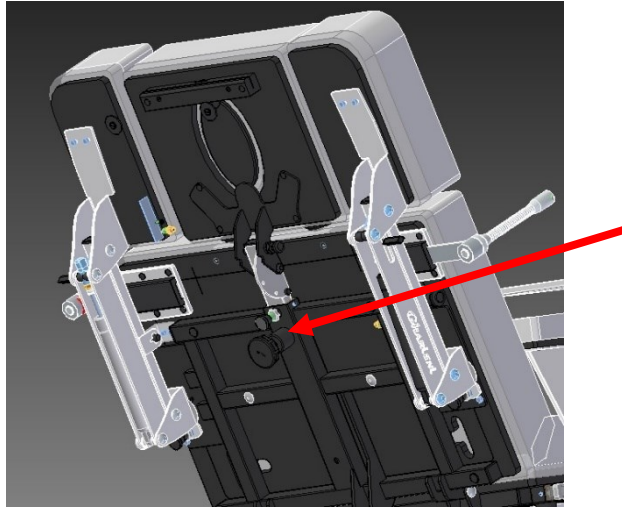

fig. 3

- ❖ The upholstery of the standard headrest is equipped with a nose slit for back massages. For this purpose, this headrest is equipped with a separate upholstered part which can be removed (see fig. 4).
- ❖ The optionally available dual headrest also has a nose slit.
- ❖ The face of the person to be treated can also be supported by placing an optional face gel cushion (see fig. 5) available from Gharieni (see also chapter 17.9 GEL PAD FOR NOSE SLITS).



fig. 4



fig. 5

*Illustration similar: The illustrations serve **only** as an example.*

10.6.1 Headrest versions

i Two additional headrests are optionally available for the 601, at an extra cost:

- a dual headrest (s. fig. 7)
 - this headrest has a round or a horn-shaped face support.
 - The scope of delivery of the dual headrest includes an air cushion with a hand pump, which allows individual adjustment of the height of the respective face supports (s. figs. 9, 10 and 11).
The inflated air cushion allows the face support to flexibly adapt to the movements of your customer in all directions.
- a U-shaped headrest (s. fig. 8 and chapter 10.6.2 INSTALLING THE U-SHAPED HEADREST).



fig. 7



fig. 8

i Both face supports of the dual headrest have a nose slit.
To obtain the nose slit on the round face support, please remove the separate upholstery part.

➤ see also chapter 17.1 HEADRESTS



fig. 9

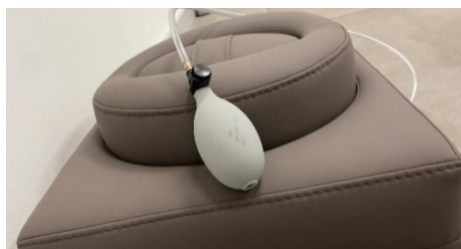

fig. 10



fig. 11

10.6.2 Installing the U-shaped headrest

INSTALLING THE HEADREST

1. Slide the tubes of the headrest (1) into the corresponding mountings (1 a) on the backrest of the 601, s. fig. below
2. Lock the headrest in place with the fastening screw (1 b).
3. Then attach the cushion (2) to the frame of the headrest (1).



1b 1 2



1a

1	HEADREST (frame)
1 a	MOUNT FOR THE HEADREST FRAME (on the backrest)
1 b	FASTENING SCREW
2	HEADREST CUSHION

i The “DENTALAX“ NECKREST is optionally available for the 601 (see chapter 17.11 NECKREST “DENTALAX”).

The “DENTALAX“ NECKREST is used for anatomical support of the cervical vertebrae and increases the feeling of lying down again considerably.

NOTICE! Do not lean against the headrest! Never stand, support, or sit on the headrest. Otherwise you may cause permanent damage to it!
RISK OF DAMAGE!

10.7 Armrests

⚠ WARNING! Never exert physical force on the armrests, regardless of the treatment table's surface setting. Non-compliance with these instructions may permanently damage the support structure. **RISK OF TIPPING! BREACH DANGER! RISK OF INJURY!**

NOTICE! Please note that the armrests must always be **in the basic position** (see fig. 6) before you adjust the position of the backrest. Otherwise the armrests may collide with the floor, get jammed and / or be seriously damaged (see fig. 7 and fig. 8).

➤ The armrests are **optionally** available.

10.7.1 Pneumatically adjustable armrests

- ❖ The armrests of the 601 can be lowered or raised individually using a gas spring („HANDS FREE OPERATION” / see also chapter 10.5 GAS SPRINGS).
- ❖ By operating the lever on the respective side and by applying slight pressure, these can also be adjusted infinitely.
- ❖ The pneumatically adjustable armrests of the 601 can also be swiveled. To do this, pull the locking pin and push the armrests outwards. Move the armrests towards the bed until the locking pin snaps in place and you hear a click.
- ❖ Hence the bed is ideal for back massages (see fig. below).
- By swiveling the armrests, you can also move closer to the head of the person to be treated during cosmetic treatments or facial massages.

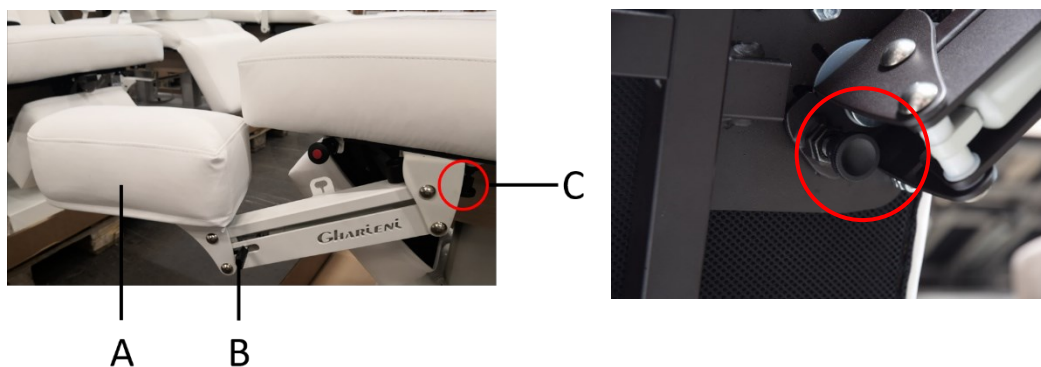

A

PNEUMATICALLY ADJUSTABLE **and** SWIVELING ARMRESTS

B	GAS SPRING LEVER of the armrest
C	LOCKING PIN

NOTICE! The armrests may only be swivelled without load! Do not lean against the armrests! Never stand, sit, or kneel on the armrests!
RISK OF DAMAGE!

NOTICE! Maximum load of the armrests is **25 kg**. RISK OF DAMAGE!

10.7.2 Additional locking mechanism of the armrests

- ❖ The armrests of the 601 can also be locked using a locking knob on the side of the bed (see fig.).
- ❖ This additional locking ensures increased stability and safety of the armrests and should be done after each treatment.

LOCKING THE ARMRESTS:

1. To lock the armrests, **push the inner red knob inwards**.
2. The armrests are now locked.

RELEASING THE LOCKING MECHANISM:

1. To release the lock, **pull the outer black knob** towards you.
2. The additional locking of the armrests is released.



Illustration similar: color, upholstery and design may vary depending on the model.

NOTICE! To swivel the armrests, the additional locking mechanism **must be released**, and the armrest **must be slightly lowered** so that they are not at the level of the locking mechanism (s. fig.). Otherwise the construction and the mechanics of the armrests can be permanently damaged. RISK OF DAMAGE!

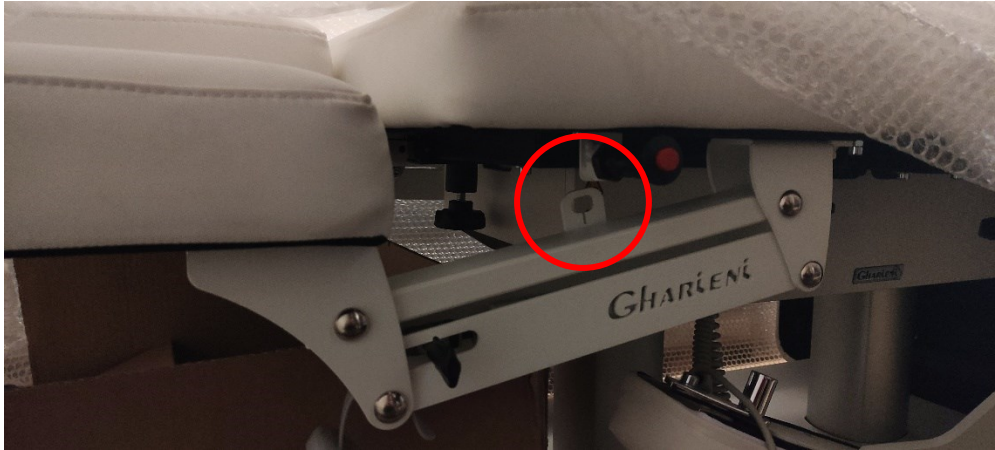

10.8 Arm supports

- ❖ The arm supports (see figure in chapter 10.4 VIEW) are always parallel to the seat.
- ❖ For lateral access and for treatments in the massage position (prone position) they can also be **swiveled down by 180°**; see illustration.
- ❖ They can also be pulled out manually.

To swivel the arm supports, proceed step by step as follows:

- Loosen the knurled screw underneath the arm support.
- Pull out the arm support to the side so that the arm support cannot collide with the seat when swiveling.
- Swivel the arm support backwards, respectively downwards by applying gentle pressure.
- Slide the arm support back up to the bed.
- Tighten the knurled screw.

➤ The arm supports are optionally available.

NOTICE! Make sure to pull out the arm supports using the knurled screw before swivelling them; otherwise you may permanently damage the upholstery of the bed! RISK OF DAMAGE!

⚠ WARNING! When swivelling the arm supports and pushing the arm supports towards the bed, make sure that there are no body parts or objects in between. RISK OF CRUSHING!

⚠ WARNING! Never exert physical force on the arm supports, regardless of the treatment table's surface setting. Always tighten the knurled screw. Otherwise the arm supports can fall out of the guide. If this instruction is not followed, the support structure of the 601 may be permanently damaged and injuries may occur. **RISK OF TIPPING! BREACH DANGER! RISK OF INJURY!**



Illustration similar: color, upholstery and design may vary depending on the model.

NOTICE! Do not lean against the arm supports! Never stand, sit, or kneel on the arm supports. Otherwise you can permanently damage them! **RISK OF DAMAGE!**

NOTICE! Maximum load capacity of the arm supports is **25 kg**.

10.9 Legrest

- ❖ The legrest of the 601 can be adjusted electrically, independently from the backrest using the hand control (see chapter 11.5 ADJUSTMENT OF THE LEGREST).

10.10 Extendable footrests

- ❖ The footrests can be pulled out manually.
- ❖ With the footrests and headrest pushed in, the length of the lying surface is approx. 180 cm.
- ❖ By extending the footrests completely and extend the headrest by approx. 5 cm, the lying surface is extended to approx. 200 cm.

NOTICE! Make sure to extend the footrests only to a point where they cannot fall out of the guide and that they are straight. **RISK OF DAMAGE! RISK OF INJURY!**

10.11 Backrest

- ❖ The backrest of the 601 is electrically adjustable (see chapter 11.3 ADJUSTMENT OF THE BACKREST).

11. Electrical adjustments

- i** The electrical adjustments of the 601 are made using a hand control.
- i** **Optionally**, the settings can also be performed using a foot control with Bluetooth (s. chapter 12. FOOT CONTROL).



For safety reasons, the treatment table only moves if you keep a button of the hand control or the optional foot control pressed. When released, the movement stops immediately.

11.1 Hand control

The hand control is a wired control.

It enables the electrically controllable functions to operated.

- i** Saving certain lying positions is described in chapter 11.7 MEMORY FUNCTIONS OF THE HAND CONTROL.
- ❖ You can control the two lifting columns and the two actuators by pressing and holding down the corresponding button.
- ❖ Furthermore, you can individually adjust, save, and recall two memory positions.
- ❖ It is also possible to recall the four pre-set positions P1 - P4.
- ❖ The hand control has 12 buttons.
- ❖ When not in use, the hand control can be stored underneath the seat, behind the armrest mount, on a holder.
- ❖ The adjustment of the working height, the backrest, the inclination of the seat area, and the legrest (buttons 'T 1 - 'T 4 on the hand control or on the optional foot control) is done by a double-tap system.
- ❖ This is for safety reasons.
A movement that is associated with danger is made consciously by this.

For the direction of movement, please note the arrow symbols and the number of dots in the upper area of the hand control.

By simply pressing a button and keeping it pressed, a movement is made upwards.

By pressing a button twice (double-tap system) and keeping it pressed, a movement is made in the opposite direction.

Storing the two individually adjustable memory positions and de-activation of the locking function is also done using the double-tap system.

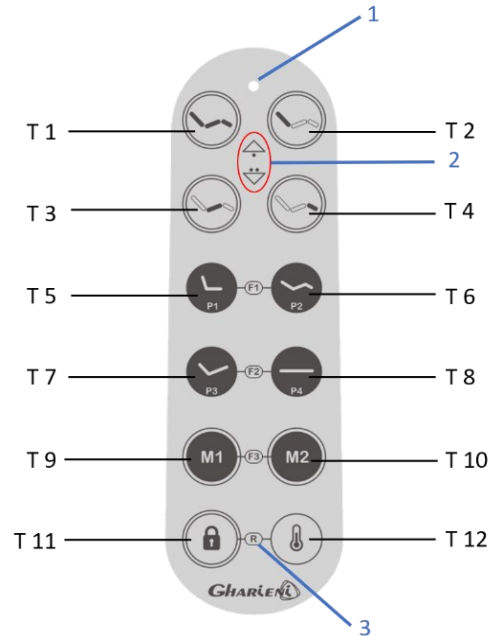

T 1	➤ Button for adjustment of the WORKING HEIGHT
T 2	➤ Button for adjustment of the BACKREST
T 3	➤ Button for adjustment of the INCLINATION OF THE SEAT AREA
T 4	➤ Button for adjustment of the LEGREST
T 5	<p><u>PROGRAM BUTTON P1</u></p> <ul style="list-style-type: none"> ➤ PROGRAM BUTTON P1 moves the 601 to the fixed entry position. ➤ <u>The entry position cannot be changed.</u>

T 6	<p><u>PROGRAM BUTTON P2</u></p> <ul style="list-style-type: none"> ➤ PROGRAM BUTTON P2 moves the 601 to the fixed S-Curved-Position. ➤ <u>The S-Curved-Position cannot be changed.</u>
T 7	<p><u>PROGRAM BUTTON P3</u></p> <ul style="list-style-type: none"> ➤ PROGRAM BUTTON P3 moves the 601 to the fixed pedicure position ➤ <u>The pedicure position cannot be changed.</u>
T 8	<p><u>PROGRAM BUTTON P4</u></p> <ul style="list-style-type: none"> ➤ PROGRAM BUTTON P4 moves the 601 to the fixed massage position (backrest retracted to the max, seat tilt retracted to the max, leg section extended to the max). ➤ <u>The massage position cannot be changed.</u>
T 9	<p><u>MEMORY BUTTON M1</u></p> <ul style="list-style-type: none"> ➤ MEMORY BUTTON M1 is used to save and recall the first individually adjusted position.
T 10	<p><u>MEMORY BUTTON M2</u></p> <ul style="list-style-type: none"> ➤ MEMORY BUTTON M2 is used to save and recall the second individually adjusted position.
T 11	<p><u>LOCK BUTTON</u></p> <ul style="list-style-type: none"> ➤ The LOCK BUTTON locks or releases the hand control / the actuators.
T 12	<p><u>BUTTON FOR THE HEATING SYSTEM</u> (optional)</p> <ul style="list-style-type: none"> ➤ With this button you can switch on the heating system, set it in 3 levels and switch it off again.

1	<p><u>LED</u></p> <ul style="list-style-type: none"> ➤ indicates the currently set heating level of the heating system. ➤ indicates a successful reset process.
2	<p><u>SYMBOLS FOR THE DOUBLE-TAP SYSTEM</u></p> <ul style="list-style-type: none"> ❖ Adjustment of the working height, the backrest, the inclination of the seat area and of the legrest (buttons T 1 - T 4) is done using the double-tap system. ❖ Storing the two individually adjustable and storable positions and de-activation of the locking function is also done using the double-tap system. ❖ This serves for safety. A movement that is associated with danger is made <u>consciously</u> by this.
3	<p><u>SYMBOL FOR RESET</u></p> <ul style="list-style-type: none"> ➤ Buttons T 11 + T 12 on the hand control simultaneously and keep them pressed until a successful reset process is indicated by the LED located in the upper area of the hand control flashing three times. ➤ s. chapter 14. RESET

⚠ WARNING! When setting the treatment position, make sure that there are no body parts or objects between the bed components.
RISK OF CRUSHING!

NOTICE! For safety reasons, the treatment table only moves if you keep a button of the hand control pressed. When released, the movement stops immediately. A movement that is associated with danger is made consciously by our double-tap system.

11.2 Adjustment of the working height

- ❖ **i** Use button **T1** to adjust the WORKING HEIGHT; s. fig. in chapter 11.1 HAND CONTROL.
 - ❖ **i** For the direction of movement, please note the arrow symbols and the number of points above on the hand control.
 - ❖ **i** Press the button once and keep it pressed to raise the 601.
Press and the button twice (double-tap system) and keep it pressed to lower it.
 - ❖ The horizontal WORKING HEIGHT of the 601 can be adjusted from approx. 59 cm to approx. 99 cm (with the stands screwed in).
 - ❖ The horizontal WORKING HEIGHT of the 601 **with soft upholstery** can be adjusted **from approx. 64 cm to approx. 104 cm** due to the slightly thicker upholstery (with the stands screwed).
 - ❖ By unscrewing the stands (up to approx. 3 cm) you raise the working height somewhat.
 - ❖ By using the optionally available lockable castors, you raise the working height by approx. 5.5 cm.
- The ENTRY HEIGHT is the lowest setting of the seat.
This is indicated in the horizontal position of the seat.
- 601 (standard upholstery) = approx. 59 cm / seat in horizontal position
 - 601 (soft upholstery) = approx. 64 cm / seat in horizontal position

To recall the fixed entry position, press program button **P1** on the hand control and keep it pressed **until** the entry position is reached.

11.3 Adjustment of the backrest

- ❖ The inclination of the backrest can also be adjusted by using the hand control.
- ❖ Use the corresponding button (**T 2**) to adjust the BACKREST; s. fig. in chapter 11.1 HAND CONTROL.
- ❖ For the direction of movement, please note the arrow symbols and the number of points above on the hand control.
- ❖ Press the button once and keep it pressed to raise the backrest.
Press the button twice (double-tap system) and keep it pressed to lower the backrest.

⚠ WARNING! When setting the treatment position, make sure that there are no body parts, objects, or persons between the bed components. **RISK OF CRUSHING!**

11.4 Adjustment of the inclination of the seat area

- ❖ The inclination of the seat area of the 601 can also be adjusted using the hand control.
- ❖ Use the corresponding button (**T 3**) to adjust the inclination of the seat area (s. fig. in chapter 11.1 HAND CONTROL resp. fig. in chapter 12. FOOT CONTROL).
- ❖ For the direction of movement, please note the arrow symbols and the number of points above on the hand control.
- ❖ Press the button once and hold it down each time to adjust the inclination of the seat area or twice (double-tap system) to adjust the seat area horizontally.

11.5 Adjustment of the legrest

- ❖ The inclination of the legrest can also be adjusted by using the hand control. The seat area must be **raised** for this purpose (see chapter 11.4 ADJUSTMENT OF THE INCLINATION OF THE SEAT AREA).
- ❖ Use the corresponding button (**T 4**) to adjust the legrest (s. fig. in chapter 11.1 HAND CONTROL).
- ❖ For the direction of movement, please note the arrow symbols and the number of points above on the hand control.
- ❖ Press the button once and keep it pressed to raise the legrest. Press the button twice (double-tap system) and keep it pressed to lower the legrest.

11.6 Locking function / locking button of the hand control

- i** The 601 is equipped with a LOCKING FUNCTION to protect against unauthorized use. The drive system itself locks automatically after 30 minutes of inactivity. The current heating cycle is not affected.
- i** Manual locking also **does not affect** the heating cycle currently running and **does not affect the operation of the heating system.**

ACTIVATION OF THE LOCKING FUNCTION:

1. To activate the locking function, press the LOCK button (**T 11**) on the hand control and **hold it down** for approx. 3 seconds.
2. The backlighting of the hand control increases in intensity. **For confirmation**, the LED above the button of the hand control lights up.
3. The drives are now locked.



DE-ACTIVATION OF THE LOCKING FUNCTION:

1. To release, press the LOCK button (**T 11**) on the hand control **twice in quick succession** and **hold it down** for approx. 3 seconds.
2. The backlighting of the hand control will now dim slightly.
3. The drives are now unlocked.



NOTICE! To prevent unauthorized use of the 601, always activate the locking function when leaving the treatment room. If you should forget to do this, the drives lock automatically after 30 minutes.

11.7 Memory functions of the hand control

- ❖ In addition to four pre-set treatment positions, the hand control of the 601 has two individually adjustable and storable positions (memory positions: M 1 / M 2).
- ❖ The memory function saves the treatment positions you have selected, thus simplifying your workflows. Use buttons M1 and M2 (see fig. in chapter 11.1 HAND CONTROL).
- ❖ Memory positions are stored in the same way as the electrical settings of the 601 using a double-tap system.

SAVING MEMORY POSITIONS M1 & M2:

1. Set the desired position as usual with buttons T1 to T4.
2. Press button M1 or M2 (double-tap system) and keep it pressed for three seconds.
3. An acoustic signal sounds when the storage has been successful. The respective memory position is now stored.



RECALLING MEMORY POSITIONS:

Press and keep the corresponding MEMORY button M1 or M2 pressed until the stored treatment position is reached.



12. Foot control with Bluetooth (optional equipment)

- ❖ A foot control with Bluetooth can be connected as an option in addition to the hand control.
- ❖ The foot control enables the adjustment of the basic functions, the approach of two permanently stored positions as well as the storage and recall of two individually adjusted memory positions.
In addition, the heating system can be operated, the bed can be locked and unlocked, and the bed software can be reset.
- ❖ The operation is done in the double-tap system, as with the hand control. This is for safety reasons. A movement that is associated with danger is made consciously by this.

For the direction of movement, please note the arrow symbols and the number of dots on the foot control.

By simply pressing a button and keeping it pressed, a movement is made upwards.

Pressing a button twice (double-tap system) and keeping it pressed makes a movement in the opposite direction.

The two individually adjustable and storable memory positions are also stored using the double-tap system.

- When purchasing a 601, the hand control is included as standard.
Optionally, for an additional charge, the foot control can be purchased.

NOTICE! Due to the surface material of the foot control, it may need to be cleaned with an alcohol-free cleaning agent on a soft cloth or paper towel. **Never** use hard sponges, pot cleaners, scouring cloths or aggressive cleaning agents such as scouring powder. Dishwashing detergent, solvents, bleach, or essential oils must also **not be used** to clean the foot control. **RISK OF DAMAGE!**

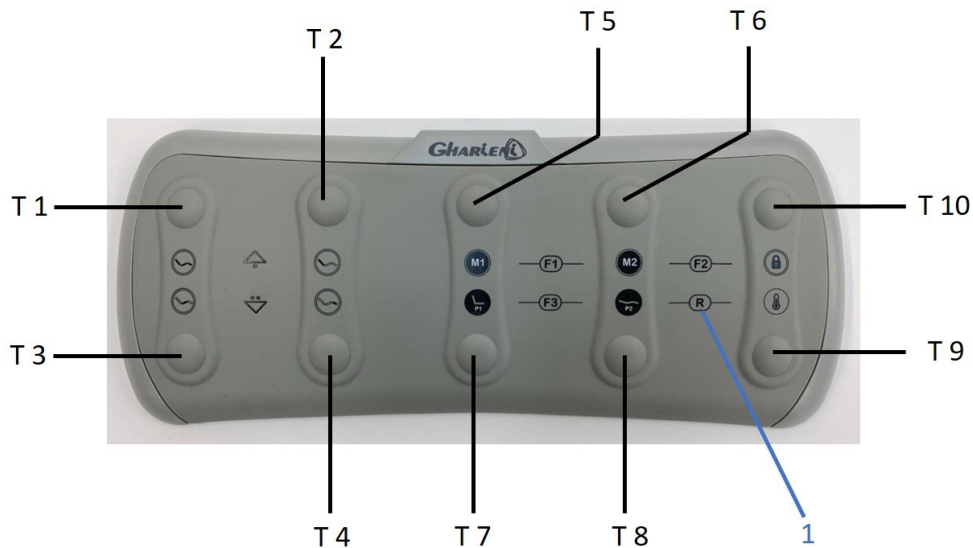

T 1	➤ Button for adjustment of the WORKING HEIGHT
T 2	➤ Button for adjustment of the BACKREST
T 3	➤ Button for adjustment of the INCLINATION OF THE SEAT AREA
T 4	➤ Button for adjustment of the LEGREST
T 5	<u>MEMORY BUTTON M1</u> ➤ MEMORY BUTTON M1 is used to save and recall the first individually adjusted position.
T 6	<u>MEMORY BUTTON M2</u> ➤ MEMORY BUTTON M2 is used to save and recall the second individually adjusted position.

<p>T 7</p>	<p><u>PROGRAM BUTTON P1</u></p> <ul style="list-style-type: none"> ➤ PROGRAM BUTTON P1 moves the 601 to the fixed entry position. ➤ <u>The entry position cannot be changed.</u>
<p>T 8</p>	<p><u>PROGRAM BUTTON P2</u></p> <ul style="list-style-type: none"> ➤ PROGRAM BUTTON P2 moves the 601 to the fixed S-curved position. ➤ <u>The S-curved position cannot be changed.</u>
<p>T 9</p>	<p><u>BUTTON FOR THE HEATING SYSTEM</u></p> <ul style="list-style-type: none"> ➤ With this button you can switch on the heating system, set it in 3 levels and switch it off again. ➤ Please refer to the table in chapter 13.1 OPERATION.
<p>T 10</p>	<p><u>LOCK BUTTON</u></p> <ul style="list-style-type: none"> ➤ The LOCK BUTTON locks or releases the foot control / drives.
<p>1</p>	<p><u>RESET</u></p> <ul style="list-style-type: none"> ➤ Press buttons T 8 and T 9 and hold them down <u>simultaneously</u> for approx. 3 seconds until a successful reset process is indicated by the LED in the upper area of the hand control flashing three times and with the LED module. ➤ The software is reset to the initial state.

12.1 LED module

When operating the optionally available heating system with the optionally available foot control with Bluetooth, the respectively set heating level is displayed with a LED module, see table and figure below.

The LED module has three rows of LEDs.

The LED module is located on the back of the treatment table, on the wooden paneling below the backrest.

The heating level set at any given time can be easily recognized with the LED module and saves a look at the hand control.

Heating Level	LED Module Display
1	first row
2	second row
3	third row
-OFF-	-OFF-



13. Heating system (optional equipment)

- ❖ The upholstery surface of the 601 can be heated to increase comfort. It is a pre-programmed and fully automatic heating system which allows comfortable operation. This heating system is integrated in the upholstery of the treatment table and works with modern microprocessor technology. For the 601, the heating system is optionally available at extra cost.
- ❖ Due to the pre-programmed microchip, you only must switch on the heating system to start the heating system with the lowest heat / power level. To quickly heat up the bed's surface before starting treatment, we recommend setting the heating system to level 3 (highest level). The heating program is fully automated and switches off automatically after a total time of 90 minutes.

➤ s. chapter 13.1 OPERATION.

- ❖ The drive system locks automatically after 30 minutes of inactivity. The heating cycle currently in process is **not affected** by this.
- ❖ Even a manual locking **does not affect** the heating cycle currently in process and has **no effect on the operation of the heating system either**.

➤ s. chapter 11.6 LOCKING FUNCTION / LOCKING BUTTON OF THE HAND CONTROL.

⚠ CAUTION! If your 601 is equipped with the optionally available heating system, do not place heavy blankets, clothing or similar on the upholstery while the heating system is switched on. **RISK OF DAMAGE! RISK OF BURNS!**

NOTICE! The currently active heating level is visualized via an LED (diode) in the middle of the upper section of the hand control. The frequency of the impulse for visualization varies accordingly.

⚠ WARNING!

1. **Do not** use the heating system in the following cases:
 - on customers with pacemakers.
 - on pregnant women.
 - on customers with thrombosis.
 - on customers suffering from pain of unknown cause.
2. Use **only** on healthy people.
3. If treatment is terminated prematurely, the heating system must be switched off by pressing the corresponding button on the hand control resp. on the optional foot control to prevent heat accumulation.
4. Disconnect the 601 from the mains if it is not used for a longer time, e.g. overnight.

⚠ WARNING! People with acute pain, venous disorders, low blood pressure, inflammatory processes and other medical conditions that make heat applications or this form of client positioning questionable **must** always consult a doctor before use.

⚠ WARNING! Never use the 601 and / or the heating system on people who are under the influence of alcohol or drugs.

⚠ WARNING! If the treatment table is equipped with the heating system (optional), the cables are located between the upholstery and the underframe. **The upholstery may only be removed by persons authorized by the Gharieni Group GmbH.**

13.1 Operation

- ❖ The heating system is operated using the button  (T 12) of the hand control.
- ❖ For operation with the optional foot control see chapter 12. FOOT CONTROL WITH BLUETOOTH (OPTIONAL EQUIPMENT).



POWER ON:

- ❖ Use this button to switch **on** the heating system.

The heating system comes with three heat / power levels.

To quickly heat up the bed's surface before starting treatment, we recommend setting the heating system to level 2; only in exceptional cases to level 3 (highest level).

Please refer to the chart below to find information on how to operate the heating system.

After a total time of **90 minutes** the heating system shuts down **automatically**; regardless of the set heating level.

- ❖ This process is pre-programmed.







POWER OFF:

- ❖ Using this button you also switch **off** the heating system.

NOTICE! If your 601 is equipped with the optionally available heating system and the optionally available foot control with Bluetooth, the heating level currently set is displayed additionally with the LED module (s. chapter 12.1 LED MODULE).

There are three heat / power levels to choose from:

		Heating level	Visualization via an LED (diode)	Heating output
button 	Push button once	Power on / level 1	single impulse on the hand control for 0.3 seconds, interval 1 second	30 %
button 	Push this button again	level 2	double impulse on the hand control , lights up for 0.3 seconds, interval 1 second	60 %
button 	Push this button again	level 3	triple impulse on the hand control , lights up for 0.3 seconds, interval 1 second	90 %
button 	Push this button again	Power off		

NOTICE! If the heating system is not present on your bed, this is signalled to you by the LED above the button of the hand control flashing quickly when you press the button to operate the heating system.

14. Reset

- i** You can reset the software of the bed to its initial state; e.g. for the complete reprogramming of treatment positions etc.

PLEASE PROCEED AS FOLLOWS:

1. Press buttons **T 11 and T 12** of the hand control **simultaneously and keep them pressed for approx. 3 seconds** until a successful reset process is indicated by the LED in the upper area of the hand control flashing three times (= **reset** / s. fig. 16).
2. The software is reset to its initial state.

- i** The LED (diode) in the upper area of the hand control **flashes three times** to visually **confirm** a successful reset process.

OR

1. Press and **hold** the buttons **T 8 and T 9 of the foot control** (see below, fig. 17) **simultaneously for approx. 3 seconds** until a successful reset process is indicated by the LED in the upper area of the foot control flashing three times.
2. The software is reset to its initial state.

- i** The LED (diode) in the upper area of the hand control **flashes three times** to visually **confirm** a successful reset process.

- i** **Stored memory positions are deleted.**

NOTICE! Always wait until the hand control signals a successful reset process by flashing the LED three times. Otherwise the reset process is not completed!

NOTICE! If your treatment table is equipped with the optionally available heating system and with the optionally available foot control, a successful reset process is signaled by all three rows of the LED module flashing three times.

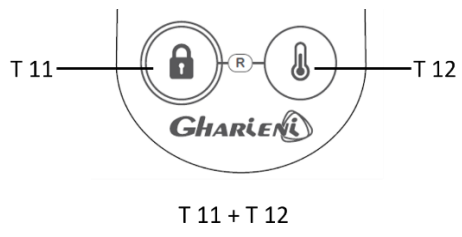

FIG. 16

ODER

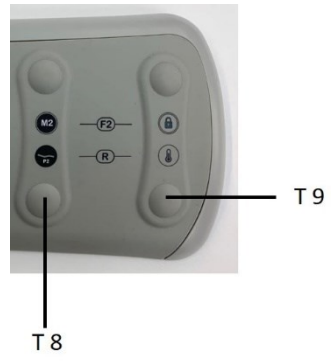

FIG. 17

15. Malfunctions (causes and troubleshooting)

MALFUNCTION	
POSSIBLE CAUSE (S)	TROUBLESHOOTING
ALL ACTUATORS DO NOT WORK.	
<ol style="list-style-type: none"> 1. No power connection. 2. Power cable defective. 3. Hand control / actuator plug not inserted properly. 4. Hand control defective. 5. Total failure of the control box. 	<ol style="list-style-type: none"> 1. Check connection status. 2. Power cable needs to be replaced (please contact customer service). 3. Check connection status. 4. Hand control must be replaced (please contact customer service). 5. Control box must be replaced (please contact customer service).
SINGLE ACTUATOR DOES NOT WORK.	
<ol style="list-style-type: none"> 1. Actuators plug not connected correctly. 2. Hand control defective. 3. Control box defective. 4. Actuator cable / plug defective. 5. Actuator defective. 	<ol style="list-style-type: none"> 1. Check connection status. 2. Hand control must be replaced (please contact customer service). 3. Control box must be replaced (please contact customer service). 4. Cable / plug must be replaced (please contact customer service). 5. Actuator must be replaced (please contact customer service).

i If the treatment table shows malfunctions differing from those described above or if you have checked all items on the list but the problem could not be solved, please contact our customer service (see also chapter 15.1 REPAIR)

15.1. Repair

**YOU CAN CONTACT GHARIENI CUSTOMER SERVICE
USING THE FOLLOWING CONTACT DETAILS:**

CUSTOMER SERVICE HOTLINE:	+49 (0)2841/88300-40
E-MAIL:	service@gharieni.com

1. Please use the form that opens after scanning the QR-Code in the Internet browser of your suitable end device if you have problems with your 601 or if you should notice any damage.
In this way you can send information to our customer service easily, simply, and quickly. See also chapter 8. QR-CODE.
2. We consider ourselves responsible for the safety and reliability of the 601 only if repairs and modifications are carried out by us or a person authorized by us. Furthermore, the electrical installation must comply with the regulations (VDE 0100 or 107) and the 601 must be used in accordance with the operating instructions.
3. In case of improper modifications or manipulations to the 601, **any** warranty on behalf of Gharieni Group GmbH is excluded.
4. The treatment table can remain connected to the mains and does not need to be disconnected from the mains for daily use.
5. Check the power cord regularly for signs of damage.
6. If the mains cable is damaged, it may only be replaced by Gharieni Group GmbH, or a customer service authorized by Gharieni Group GmbH or a qualified specialist (electrical engineer).

⚠ DANGER! In case of defects or malfunctions of the treatment table, contact customer service **immediately**. Use of the treatment table **must** be discontinued until the problem has been solved to avoid further damage to property and persons.

16. Cleaning and Care

⚠ WARNING! Always disconnect the 601 from the power supply before all maintenance and cleaning work (pull the power plug). FIRE HAZARD!

⚠ WARNING! Regularly remove any dust build-up from the mains plug, the safety socket and all electrical plug connections, e.g. with a commercially available vacuum cleaner. RISK OF FIRE!

⚠ WARNING! Always ensure that water or other liquids **never** enter the housing and fittings of the 601 or the hand control. RISK OF ELECTRIC SHOCK! FIRE HAZARD!

NOTICE! Damage to the bed, the upholstery and / or the material of the base / support structure caused by use of unsuitable cleaning agents **is not covered by the warranty!**

- ❖ Before performing any cleaning or maintenance work on the 601, please remove all hand and arm jewellery (rings, bracelets etc.). Otherwise you could accidentally scratch and / or damage the upholstery and / or the material of the base.
- ❖ Use **only** water or a mild cleaning agent suitable for the respective material.
- ❖ **Do not** use hot water to clean the 601.
- ❖ **Never** use hard sponges, pot cleaners or abrasive cloths.
- ❖ **Never** use aggressive cleaning agents such as scouring powder, floor cleaner etc.
- ❖ **Never** use dish detergent.
- ❖ **Never** use solvents or bleach.
- ❖ **Never** use essential oils for cleaning.

16.1 Cleaning the PU upholstery

- ❖ Clean the PU **only** with a soft cloth with a small amount of a detergent suitable for this material (also available from Gharieni: see chapter 18. UPHOLSTERY CARE AND CLEANING AGENTS).

16.2 Cleaning and care of the Ferrari Stamskin

- ❖ Clean the artificial leather **only** with a soft cloth with a small amount of a detergent suitable for this material (also available from Gharieni: see chapter 18. UPHOLSTERY CARE AND CLEANING AGENTS).

NOTICE! The upholstery of the 601 can also be Ferrari Stamskin Top. This material can be cleaned with a cloth with some detergent, which must be suitable for this material.

16.3 Cleaning the housing and the fittings

- ❖ Clean the housing and the fittings **only** with a soft cloth with a small amount of a detergent suitable for this material (also available from Gharieni: see chapter 18. UPHOLSTERY CARE AND CLEANING AGENTS).

⚠ WARNING! Always make sure that water or other liquids **never** enter the housing, fittings, or the hand control of the 601.
RISK OF ELECTRIC SHOCK! FIRE HAZARD!

17. Optional equipment / optional accessories

- ★ For detailed information regarding the optionally available accessories (s. below) please contact our sales department. Our team is happy to help!

17.1 Headrests

The 601 does not feature a headrest as standard. When purchasing the 601, please choose from one of the following three designs:

17.1.1 Standard headrest



- ❖ The upholstery of the standard headrest is equipped with a nose slit for back massages. For this purpose, this headrest is equipped with a separate upholstered part which can be removed.

17.1.2 Dual headrest



This newly designed headrest offers full flexibility for every requirement. This headrest has a round or a horn-shaped face cushion.

The scope of delivery of the dual headrest includes an air cushion including a hand pump, which allows individual adjustment of the height of the respective face cushion; s. figs.



FIG. 1



FIG. 2



FIG. 3

17.1.3 U-shaped headrest



The U-shaped headrest is mounted in the corresponding mounts on the backrest of the treatment bed.

- s. also chapter 10.6.2 INSTALLING THE U-SHAPED HEADREST.
- ★ Please contact our sales department regarding the desired version of the headrest for your treatment table. Our team is happy to help!

17.2 Foot control

- ❖ A FOOT CONTROL with Bluetooth is optionally available for the 601 at an additional charge.
- ❖ The FOOT CONTROL allows you the adjustment of the basic functions, the approach of two fixed pre-set positions as well as the storage and recall of two individually adjusted memory positions.
In addition, the heating system can be operated, the bed can be locked and unlocked, and the bed software can be reset.
 - s. also chapter 12. FOOT CONTROL WITH BLUETOOTH (OPTIONAL EQUIPMENT).

17.3 Castors

- ❖ Castors are optionally available for the 601; for an additional charge.
- ❖ When using the castors, the working height is increased by 5.5 cm.
 - s. also chapter 6.2 TRANSPORT



CASTOR SET, BREAKABLE

ITEM NUMBER: 73006

17.4 Mount for (magnifying) lamps

- ❖ The extendable mount for (magnifying) lamps made of stainless steel is **optionally** available for the 601. When not in use, it simply disappears under the treatment table. The matching LED magnifying lamp „Circle“ allows precise work.



MOUNT
FOR (MAGNIFYING) LAMPS

ITEM NUMBER: 41999-R-L-MO1-SC / WE

17.5 LED magnifying lamp „Circle“

- ❖ The magnifying lamp „Circle“ is available **as an option** for the 601.



LED MAGNIFYING LAMP „CIRCLE“
ITEM NUMBER: 41999

VERSION WITH PLEXIGLASS PANEL
ITEM NUMBER: 41999-SHIELD

- ★ Please refer to the separate instruction and assembly manual.

17.6 Manicure bowl

- ❖ The manicure bowl is **optionally** available for an additional charge. It can easily be attached using the supplied circle-shaped holder; on the arms there already is a suitable holder in which you can insert the supplied holder.

➤ See also chapter 10.4 VIEW, ITEM # 6.



MANICURE BOWL
ITEM NUMBER: 42020

HOLDER FOR MANICURE BOWL
ITEM NUMBER: 42020

17.7 Sheet metal for the headrest (privacy screen)

- ❖ **Optionally**, a sheet metal is available for the 601 which serves as a privacy screen for treatments in the prone position (massage position).
- ❖ It is attached to the underside of the headrest using a rail.
- ❖ When not in use, the sheet metal can be stowed under the legrest using a second rail of the same kind.

17.8 Paper roll incl. holder

- ❖ Optionally, for an additional charge, a paper roll including holder is available, s. fig.
- ❖ The holder is attached to the underside of the backrest.
- ❖ If required, the entire lying surface can be covered.



17.9 Gel pad for nose slits

- ❖ GEL PADS for the headrest of the 601 are optionally available for an additional charge.
- ❖ GEL PADS are available in different versions.
- ❖ Optimal for the prone position (massage position).
- ❖ The face of the person to be treated can be additionally supported by placing GEL PADS (see illustration below) on the padding of the headrest.
- ❖ Using a GEL PAD can also prevent unpleasant pressure marks on the face of your customers.
- ❖ The soft gel fluid cools the face comfortably.

➤ See also chapter 10.6 HEADREST



GEL PAD FOR NOSE SLITS

ITEM NUMBER: 45010

- ★ Please contact our sales department regarding the correct size and design for your bed. Our team is happy to help!

17.10 Nose slit cloths (disposable cloths)

- ❖ DISPOSABLE CLOTHS for the nose slit of the headrest of the 601 (s. fig. below) are optionally available for an additional charge.
- ❖ The disposable cloths are handy, hygienic, extra soft and protect the upholstery of the headrest of your treatment table.
- ❖ We recommend the DISPOSABLE CLOTHS for **all** headrests which are equipped with a nose slit.
- ❖ The disposable cloths are available in different sizes; up to overlength that covers the entire width of the treatment table including the armrests.



- i** Please contact our sales department regarding the appropriate or desired size and style of DISPOSABLE CLOTHS for your treatment table. Our team is happy to help!

17.11 Neckrest "Dentalax"

- ❖ Our popular „DENTALAX“ NECKREST (see illustration below) is also available for the 601 as an option.
- ❖ The „DENTALAX“ NECKREST is used for anatomical support of the cervical vertebrae.
- ❖ The „DENTALAX“ NECKREST is available in White or colored.
- ❖ The „DENTALAX“ NECKREST increases the feeling of reclining considerably: „SMALL PART, BIG EFFECT!“.



Illustration similar: color and design may vary depending on the selected model.

- ★ Please contact our sales department regarding the suitable and desired style of our „DENTALAX“ NECKREST for your treatment table. Our team is happy to help!

17.12 Protective covers

17.12.1 Terry cloth covers

- ❖ TERRY CLOTH COVERS are optionally available for our treatment table 601; for an additional charge (see fig. below).
- ❖ The TERRY CLOTH COVERS are available as a 5-piece set, with or without an oil-repellent coating made of polyurethane (PU).
- ❖ The TERRY CLOTH COVERS are suitable for standard cosmetic applications (e.g. facial treatments).
- ❖ With the covers specially made for our beds, your equipment is perfectly protected against dirt and exposure.
- ❖ The high-quality terry material enables machine washing at up to 60° C and thus hygienic cleaning.
- ❖ With their integrated elastic bands, the individual segments stay exactly where they belong, and the function of the bed is fully retained.
- ❖ Our covers are available in three different colors: White, Choco and Macchiato.
- ❖ It is best to order the correct cover when purchasing the bed.



*Illustration similar: Illustration **only** serves as an example.*

- ❖ Our covers are available in three different colors: White, Choco and Cream.
- ❖ It is best to order the matching cover directly with the purchase of your bed.
- ★ Please contact our sales department regarding the correct size and design of the covers and the compatibility with your treatment table. Our team is happy to help!

17.12.2 Protective covers made of polyurethane (PU)

- ❖ POLYURETHANE (PU) PROTECTIVE COVERS are optionally available for our s treatment tables; for an additional charge (see figure below).
- ❖ A protective cover made of PU serves as a second outer skin for the treatment tables.
- ❖ PU PROTECTIVE COVERS are suitable for massages with small amounts of oil.
- ❖ The COVERS protect the upholstered surface (outer material) of your treatment table from oil stains and prevent oil from penetrating into the actual upholstery.
- ❖ The PU COVERS are also robust, water- and oil-repellent and washable up to 90 °C.



*Illustration similar: Illustration **only** serves as an example.*

- ★ Please contact our sales department regarding the correct size and design of the covers and the compatibility with your treatment table. Our team is happy to help!

17.12.3 Foot protective cover

- ❖ This PROTECTIVE COVER FOR THE FEET AREA (s. fig. below) of your treatment table is optionally available for an additional charge.
- ❖ It is made of stable, transparent plastic and is attached with Velcro / counter-Velcro.
- ❖ The COVER protects the foot area of your bed from dirt (e.g. from shoes).



FOOT PROTECTIVE COVER

ITEM NUMBER: 49052

NOTICE! We recommend ordering the foot protective cover **directly with the purchase of your treatment table**. In this case, the counter-Velcro is already attached to the treatment table upon delivery so that you can easily and comfortably attach the foot protective cover. If you order the foot protective cover later, you must attach the **counter-Velcro** to the treatment table **on your own responsibility**.

- i** If you would like to order a foot protective cover for your treatment table afterwards, please **indicate** that **the counter-Velcro should be included** during the ordering process.

18. Upholstery care and cleaning agents

18.1 mikroqid[®] sensitive (alcohol-free)

- ❖ We recommend mikroqid[®] sensitive for gentle and thorough disinfection, care, and cleaning of the upholstery.
- ❖ mikroqid[®] sensitive removes bacteria, fungi, and viruses (e.g. HBV, Rota, Vaccinia etc.).
- ❖ mikroqid[®] sensitive is available as liquid.
- ❖ **Suitable for cleaning of PU and artificial leather upholstery.**
- ❖ **Without alcohol!**
- ❖ Please follow the manufacturer's application instructions on the bottle.



MIKROZID[®] SENSITIVE: LIQUID

ITEM NUMBER: 79417

Microbiological efficacy

Efficacy	Concentration	Contact time
bactericidal EN13727 - dirty conditions	ready-to-use	1 min.
bactericidal in accordance with VAH Guidelines with short contact times	ready-to-use	1 min.
bactericidal EN16615 - dirty conditions	ready-to-use	1 min.

Efficacy	Concentration	Contact time
yeasticidal EN16615 - clean conditions	ready-to-use	1 min.
yeasticidal EN13624 - dirty conditions	ready-to-use	1 min.
virucidal against enveloped viruses in accordance with DVV (German Registered Association for Combating Viral Diseases)//RKI Guideline	ready-to-use	1 min.
Norovirus EN14476	ready-to-use	15 min.
Polyoma SV40 in accordance with DVV (German Registered Association for Combating Viral Diseases)//RKI Guideline	ready-to-use	1 min.
Rotavirus	ready-to-use	1 min.

Certificates

- VAH certificate
- IHO listed



For more information, visit the manufacturer's website at the following link:
<https://www.schuelke.com/intl-en/products/mikrozid-sensitive-liquid.php>

18.2 Skai cleaner

- ❖ For gentle and thorough care and cleaning of the artificial leather upholstery we additionally recommend Skai cleaner.
- ❖ Skai cleaner is available in a 200 ml spray bottle.
- ❖ **Especially suitable for cleaning artificial leather.**



SKAI CLEANER

ITEM NUMBER: 79427

19. Conditions of transport, storage, and operation

19.1 Transport (with / without castors)

- ❖ On a level surface, the 601 can be moved or transported using its optional castors (see chapter 6.2 TRANSPORT).
- ❖ **You must not** use the optional castors of the 601 on uneven surfaces. In this case, lift the 601 with one person at each corner of the base **only** when transporting it (see chapter 6.2 TRANSPORT).
- ❖ Never lift the 601 by the seat / lying surface or the armrests during transport; otherwise you can seriously damage the 601.
- ❖ When transporting, bear in mind the total weight of the 601 which is approx. 120 kg, so that several people are required for transport.
- ❖ When transporting the 601, always consider its dimensions. Narrow corridors, doors or stairs etc. may make transport difficult or impossible.
- ❖ The bed can also be tilted 90° (sideways) so that it can be transported through e.g. narrow door frames.

19.2 Ambient conditions for storage and transport

TEMPERATURE	from -10 °C to +50 °C (ambient temperature)
ATMOSPHERIC PRESSURE	from 700 to 1060 hPa
RELATIVE HUMIDITY	from 20 % to 90 % at +30 °C non-condensing

19.3 Ambient conditions for operation

TEMPERATURE	from +5 °C to +45 °C (ambient temperature)
ATMOSPHERIC PRESSURE	from 700 to 1060 hPa
RELATIVE HUMIDITY	from 30 % to 75 % at 30 °C non-condensing

20. Technical Data

20.1 Treatment table 601

601 / GENERAL DATA	
Minimum length (actuator of the backrest fully retracted, actuator of the legrest fully extended, headrest and footrests retracted)	184 cm
Maximum length (actuator of the backrest fully retracted, actuator of the legrest fully extended, headrest extended to maximum by 7 cm, footrests extended to maximum)	205 cm
Total upholstery width Small	75 cm
Total upholstery width Medium Small	80 cm
Total upholstery width Medium	85 cm
Adjustable height	approx. 59 cm - 99 cm (standard upholstery) approx. 64 cm - 104 cm (soft upholstery)
Inclination of the headrest	+10° / 0° / -10° / -20° / -90°
Inclination of the backrest	approx. 0° - 70°
Inclination of the legrest	approx. 0° - 90°
Inclination of the treatment table	approx. +/- 20°
Swivel range of the armrests	0° - 140°
Swivel range of the arm supports	0° - 180°
Maximum extension range of the headrest	7 cm
Extension range of the footrests	14 cm
Lifting capacity	approx. 250 kg
Maximum load capacity of the lying surface	approx. 300 kg
Maximum load capacity of the armrests/arm supports	25 kg
Total weight (without options)	approx. 120 kg

❖ Subject to technical changes.

20.2 Drives

<u>DRIVES INCL. CONTROLS</u>	
Power supply	100-240 V AC/50-60 Hz
Power consumption	approx. 270 Watt max.
Duty cycle (drives)	10 % max. 2 min. continuous operation / 18 min. break
Hand control	Coiled cable
A-weighted sound pressure level L_{PA}	≤ 35 dB (A)
Device protection class	I
Level of protection against penetration of substances	Lifting columns: IP X4 Control unit: IP 66 Actuators : IP 54

❖ Subject to technical changes.

20.3 Heating system

Power supply	100-240 V AC/50-60 Hz
Power consumption	90 Watt max.

❖ Subject to technical changes.

21. Disposal

- 1 While unpacking, the packaging materials should be kept away from children, pets, and persons with reduced mental capabilities. **CHOKING HAZARD! RISK OF INJURY!**
- 2 At the end of its service life, this product must not be disposed of with normal household waste but must be returned to a collection point for recycling electronic and electrical devices. The corresponding symbol on the product must not be removed.
- 3 **Never** expose to open flames.
- 4 Before disposal, the 601 should be cleaned thoroughly to protect people, the environment, and materials.
- 5 Before you dispose of a treatment table, **make sure that it is inoperative!** This means you should always pull the power plug and then cut off the power cable on the treatment table and remove and dispose of it directly with the power plug!
- 6 The 601 consists, among other things, of metal and plastic components and electric cables. The individual materials must be disposed of in accordance with the environmental and disposal regulations of the respective countries.
- 7 Dispose of paper and cardboard in the containers provided.
- 8 Dispose of plastics in the containers provided.
- 9 If there are no suitable disposal containers in your area, take these materials to a suitable municipal collection point.
- 10 For more information, please contact your specialist dealer, your local waste disposal facility or:

Gharieni Group GmbH

- | | |
|-----------------------------|-----------------------|
| ➤ Phone: | +49 (0)2841/88300-0 |
| ➤ Fax: | +49 (0)2841/88300-999 |
| ➤ Customer service hotline: | +49 (0)2841/88300-40 |
| ➤ E-mail: | service@gharieni.com |



Materials labelled with this symbol are recyclable.



You can obtain all available information on waste separation from your local authorities.

22. Warranty

The following warranty provisions apply to new goods worldwide.

Gharieni Group GmbH grants on new treatment tables of the 601 series, from date of purchase

- a 10-years warranty on the metal frames
- a 5-years warranty on the actuators/motors and
- a 3-years warranty on other components

in accordance with the conditions described below.

22.1 Exclusions from warranty



According to general duty of care, the recipient of the product is obliged to perform a functional test within 3 days. If malfunctions are found, this must be reported immediately to Gharieni Group GmbH. Possible later technical or optical defects cannot be considered.

Wearing parts (such as e.g. all types of lamps as well as glass panels, consumables such as terry products, etc.) are not covered by this warranty.

Furthermore, no warranty claims will be granted if:

- damage has been caused by improper use of the 601 and its components.
- damage of the 601 and its components has been caused by gross negligence.
- the malfunctioning is attributable to the operator.
- any stickers (such as e.g. the rating plate, instruction notices, etc.) have been removed.
- supplied equipment / appliances, parts of the 601 or supplied equipment / appliances are opened without explicit permission by the operating instructions (e.g. for cleaning).
- the instructions in this instruction manual have not been followed.
- the 601 has suffered changes after repair operations performed by a third party unauthorised by Gharieni Group GmbH.

23. EC-Declaration of Conformity

EC-Declaration of Conformity		
<p>We,</p> <p>Gharieni Group GmbH Gutenbergstraße 40 47443 Moers / Germany</p> <p>hereby declare, in sole responsibility, that, due to its design and construction, the device named below complies with the relevant, fundamental safety and health requirements of the EU.</p>		
(Type or model, name)		
	<p>Lifting column beds</p> <p>Lina Select; MLX Quartz; MLX Limber; PediSpa series; MLR Wet; MLW Space; MLX iDome (MLX i³(Cube) Dome; MLR; MLX;RLL series; Ellipse; 601, E-Line, 601 Podo</p>	<p>2022</p>
<p>Relevant EU directives and harmonized standards used:</p> <p>2006 / 42 / EU Machinery Directive</p> <p>2014 / 35 / EU Low Voltage Directive</p> <p>2014 / 30 / EU Electromagnetic Compatibility Directive</p> <p>2011 / 65 / EU RoHS Directive</p> <p>DIN EN ISO 12100 (2011) Safety of machinery - general principles for design Risk assessment and risk reduction</p>		
<p>Responsible for documents:</p> <p>Mohammad Abbassi Gutenbergstraße 40 47443 Moers / Germany</p>	<p>Manufacturer's signature:</p> <p>Sammy Gharieni, CEO</p> 	<p>Place and date:</p> <p>Moers, 01.02.2022</p>

24. Status of Edition

EDITION	ALTERATIONS (PAGES)	DATE
First Edition	-	23.05.2022



NOTES

THE OWNERSHIP RIGHTS TO THIS INSTRUCTION MANUAL ARE RESERVED. REPRODUCTION OR TRANSFER TO THIRD PARTIES IS PROHIBITED WITHOUT THE CONSENT OF GHARIENI GROUP GMBH. GHARIENI GROUP GMBH RESERVES THE RIGHT TO PROTECT ITS PROPERTY RIGHTS AND TO PROSECUTE ANY MISUSE.

SALES AND SHOWROOM	PRODUCTION, PICK-UP AND REPAIR
Gharieni Group GmbH Gutenbergstraße 40 47443 Moers / Germany	Gharieni Group GmbH Am Schürmannshütt 24 47441 Moers / Germany